

	A x B			
1		50 x 80 mm	756 01	756 61
2		50 x 130 mm	756 03	756 61
3		50 x 180 mm	756 06	756 61

1

50 x 80

50 x 130

50 x 180

2

3

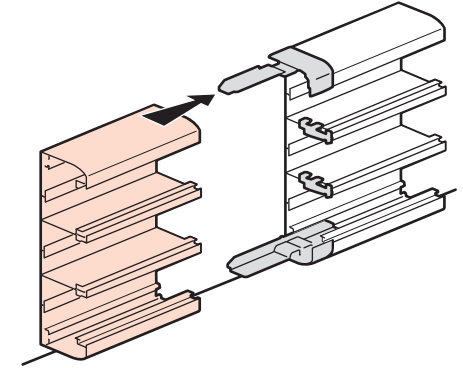
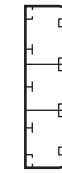
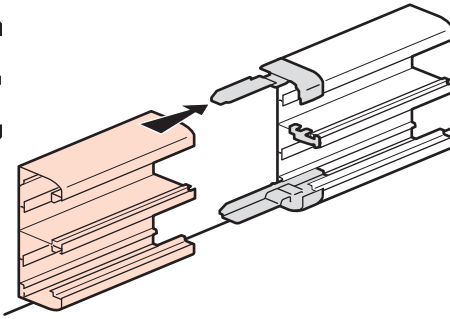
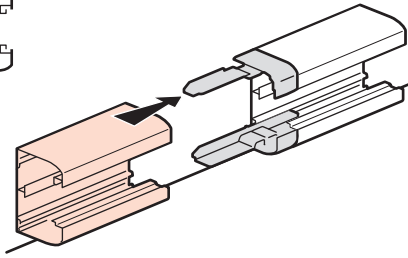

4

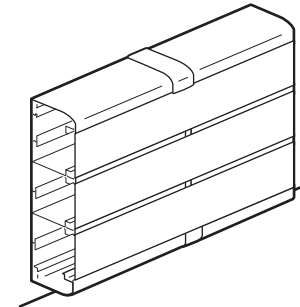
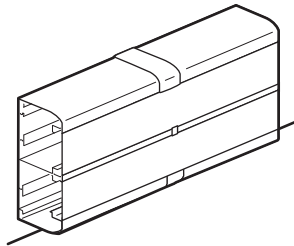
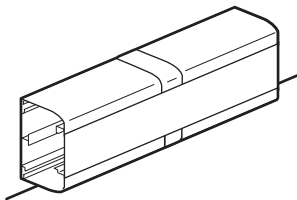
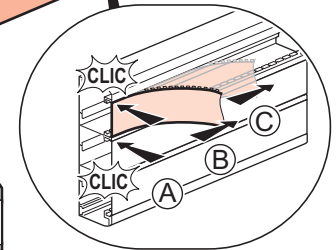
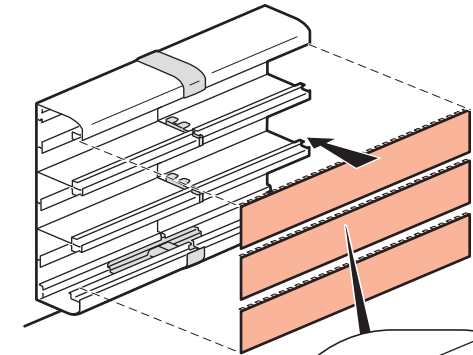
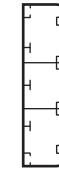
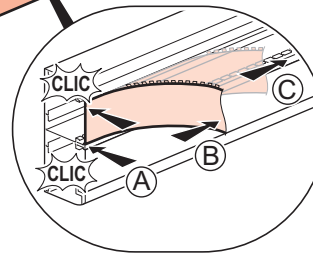
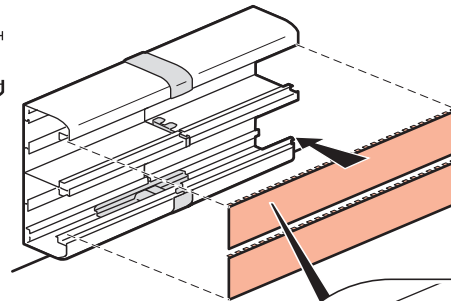
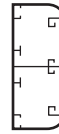
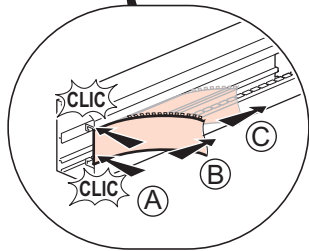
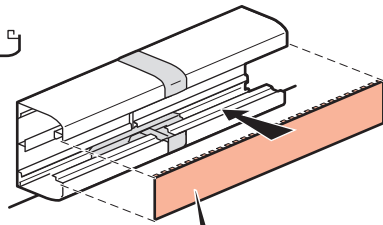

(FR) (LU) (BE) Respecter strictement les conditions d'installation et d'utilisation.
 (NL) (BE) Neem de installatie- en gebruiksvoorwaarden nauwgezet in acht.
 (GB) (IE) Strictly comply with instructions for installation and use.
 (DE) (AT) (LI) Einbau- und Gebrauchsanleitungen sind genau zu beachten.
 (ES) Respetar estrictamente las condiciones de instalación y de utilización.
 (IT) Rispettare scrupolosamente le condizioni d'installazione e uso.

(PT) Respeitar estrictamente as condições de instalação e de utilização.
 (GR) (CY) Τηρήστε αυστηρά τις συνθήκες εγκατάστασης και χρήσης.
 (PL) Ścisłe przestrzegać instrukcji dotyczących instalacji i użytkowania.
 (TR) (CY) Yerleştime ve kullanım koşullarına titizlikle riayet ediniz.
 (HU) Tartsa be pontosan a beszerelési és használati feltételeket.
 (FI) Noudata asennus- ja käyttöohjeita tarkoin.

(SE) Iaktta noggrant installations- och användningsföreskrifterna.
 (CZ) Důsledně dodržujte instalační a uživatelské podmínky.
 (SK) Prísne dodržiavajte podmienky, za ktorých sa má prístroj inštalovať a používať.
 (SI) Natančno upoštevajte pogoje za montažo in uporabo.
 (DK) Installations- og anvendelsesbetingelserne skal overholdes nøje.
 (MT) Imxi skond l-istruzzjonijiet mogħtija għall-istallazzjoni u l-użu.

(EE) Pidage täpselt kinni paigaldus- ja kasutamistingimustest.
 (LV) Stingri ievērot uzstādīšanas un lietošanas noteikumus.
 (LT) Griežtai laikytis instaliavimo ir naudojimo sąlygų.
 (NO) Installasjons- og bruksbetingelsene må nøye overholdes.
 (IS) Fylgja skal vandlega öllum reglum um uppsetningu og notkun.