

BTAL40DC
Neige
PRISE TÉLÉVISION

ALTEGE™

blucino

legrand®

Pro & Consumer Service
BP 30076 - 87002 LIMOGES CEDEX FRANCE
www.legrand.fr

Design & Quality by LEGRAND (France)

Pour fiche TV 9,52 mm
Compatible qualité UHD (4K)
Blindage Class A (4G protégé)
Atténuation < 1 dB

Produit vendu complet avec griffes démontables

Boîte à encastrer profondeur 40 mm conseillée

* En rénovation : pour fixation du mécanisme dans une boîte sans vis

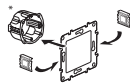

Télévision



Fixation
à vis



Schéma de câblage
à l'intérieur



CONSIGNE POUR VOTRE LOCALITEMENT > WWW.CONSIGNESETRI.FR

2 ans
GARANTIE

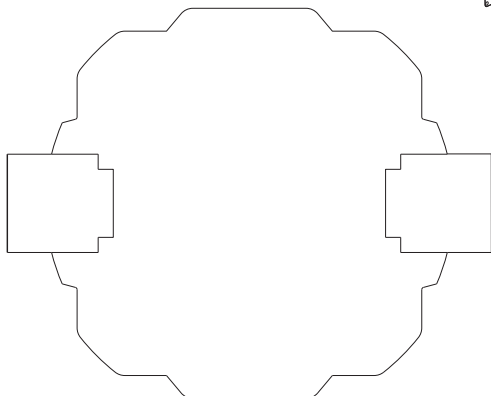

Made in France



8 005543 601266

⚠ Respecter strictement les conditions d'installation et d'utilisation.

LE10014AA

Démontage

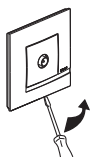

Montage

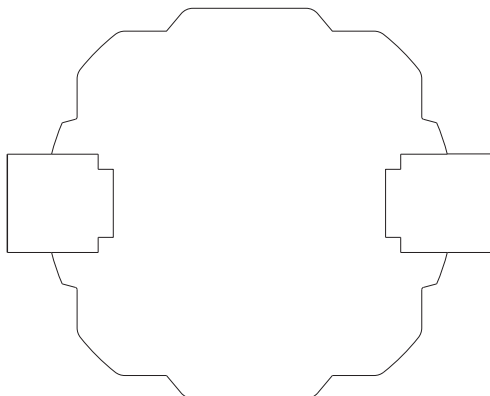
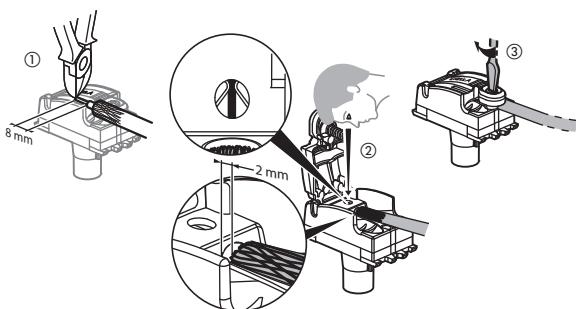
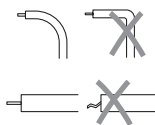
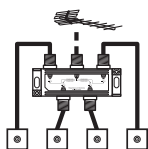
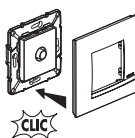

Utiliser un câble coaxial
Ø 5,5 à 7 mm - 75Ω

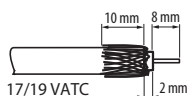

17/19 VATC