



VigiPacT RM12T

- EN** Installation manual
- FR** Notice d'installation
- DE** Montageanleitung
- IT** Manuale d'installazione
- ES** Instrucciones de instalación
- PT** Manual de instalação
- RU** Руководство по установке
- ZH** 安装手册

Multiplexer
Multiplexeur
Multiplexer
Multiplexer
Multiplexador
Multiplexador
Мультиплексор
多路转接器

 	www.se.com
	VigiPacT RMH User Guide
	en DOCA0108EN
	fr DOCA0108FR
	es DOCA0108ES
zh DOCA0108ZH	



Safety instructions / Consignes de sécurité / Sicherheitshinweise / Informazioni di sicurezza / Información de seguridad / Instruções de segurança / Указания по безопасности / 安全说明

<p>PLEASE NOTE</p> <ul style="list-style-type: none"> ■ Electrical equipment should be installed, operated, serviced, and maintained only by qualified personnel. ■ No responsibility is assumed by Schneider Electric for any consequences arising out of the use of this material. 	<p>REMARQUE IMPORTANTE</p> <ul style="list-style-type: none"> ■ L'installation, l'utilisation, la réparation et la maintenance des équipements électriques doivent être assurées par du personnel qualifié uniquement. ■ Schneider Electric décline toute responsabilité quant aux conséquences de l'utilisation de ce matériel. 	<p>BITTE BEACHTEN</p> <ul style="list-style-type: none"> ■ Elektrische Geräte dürfen nur von Fachpersonal installiert, betrieben, bedient und gewartet werden. ■ Schneider Electric haftet nicht für Schäden, die durch die Verwendung dieses Materials entstehen. 	<p>NOTA</p> <ul style="list-style-type: none"> ■ Manutenzione, riparazione, installazione e uso delle apparecchiature elettriche si devono affidare solo a personale qualificato. ■ Schneider Electric non si assume alcuna responsabilità per qualsiasi conseguenza derivante dall'uso di questi prodotti.
---	---	---	--

⚠ ⚠ DANGER / DANGER / GEFAHR / PERICOLO

<p>HAZARD OF ELECTRIC SHOCK, EXPLOSION OR ARC FLASH</p> <ul style="list-style-type: none"> ■ Apply appropriate personal protective equipment (PPE) and follow safe electrical work practices. See NFPA 70E, CSA Z462 or local equivalent. ■ This equipment must only be installed and serviced by qualified electrical personnel. ■ Turn off all power supplying this equipment before working on or inside equipment. Lock the switchgear in the isolated position. ■ Always use a properly rated voltage sensing device to confirm power is off. ■ Install safety barriers and display a danger sign. ■ Replace all devices, doors, and covers before turning on power to this equipment. <p>Failure to follow these instructions will result in death or serious injury.</p>	<p>RISQUE D'ÉLECTROCUTION, D'EXPLOSION OU D'ÉCLAIR D'ARC ELECTRIQUE</p> <ul style="list-style-type: none"> ■ Portez un équipement de protection personnelle adapté et respectez les consignes de sécurité électrique courantes. Reportez-vous aux normes NFPA 70E, CSA Z462 ou aux textes équivalents applicables dans votre région du monde. ■ Seul un personnel qualifié doit effectuer l'installation et l'entretien de cet appareil. ■ Débranchez toutes les sources d'alimentation de cet équipement avant d'effectuer toute opération interne ou externe sur celui-ci. Verrouillez l'appareillage en position isolée. ■ Utilisez toujours un dispositif de détection de tension ayant une valeur nominale appropriée pour vous assurer que l'alimentation est coupée. ■ Installez des barrières de sécurité et affichez un signal de danger. ■ Remettez en place tous les équipements, les portes et les capots avant de remettre l'appareil sous tension. <p>Si ces directives ne sont pas respectées, cela entraînera la mort ou des blessures graves.</p>	<p>GEFAHR VON ELEKTRISCHEM SCHLAG, EXPLOSION ODER LICHTBOGEN</p> <ul style="list-style-type: none"> ■ Tragen Sie persönliche Schutzausrüstung (PSA) und befolgen Sie sichere Verfahren im Umgang mit Elektrogeräten. Siehe NFPA 70E, CSA Z462 oder lokale Entsprechung. ■ Diese Geräte dürfen nur von qualifizierten Elektrikern installiert und gewartet werden. ■ Schalten Sie vor Arbeiten am bzw. im Innern des Geräts die gesamte Spannungsversorgung ab. Die Schaltanlage in die Trennstellung bringen. ■ Verwenden Sie für die Prüfung vorhandener Spannung stets einen Spannungsfühler mit zutreffender Bemessungsspannung. ■ Bringen Sie Sicherheitsbarrieren und einen Warnhinweis an. ■ Bringen Sie alle Vorrichtungen, Türen und Abdeckungen wieder an, bevor Sie das Gerät einschalten. <p>Die Nichtbeachtung dieser Anweisungen führt zu Tod oder schweren Verletzungen.</p>	<p>RISCHIO DI FOLGORAZIONE, ESPLOSIONE O BAGLIORI DA ARCO</p> <ul style="list-style-type: none"> ■ Utilizzare dispositivi di protezione individuale (DPI) idonei e adottare misure di sicurezza adeguate per lavori elettrici. Vedere le normative NFPA 70E, CSA Z462 o le norme equivalenti nel paese di installazione. ■ Installazione e manutenzione di questa apparecchiatura si devono affidare solo ad elettricisti qualificati. ■ Prima di lavorare con l'apparecchiatura o al suo interno isolare completamente l'alimentazione elettrica. Bloccare l'interruttore in posizione isolata. ■ Per verificare che l'alimentazione sia isolata usare sempre un rilevatore di tensione correttamente tarato. ■ Installare barriere di sicurezza e apporre un segnale di pericolo. ■ Sostituire dispositivi, sportelli e coperture prima di riaccendere l'alimentazione dell'apparecchiatura. <p>Il mancato rispetto di queste istruzioni provocherà morte o gravi infortuni.</p>
---	--	--	--

Safety instructions / Consignes de sécurité / Sicherheitshinweise / Informazioni di sicurezza / Información de seguridad / Instruções de segurança / Указания по безопасности / 安全说明

<p>TENGA EN CUENTA</p> <ul style="list-style-type: none"> ■ La instalación, manejo, puesta en servicio y mantenimiento de equipos eléctricos deberán ser realizados sólo por personal cualificado. ■ Schneider Electric no se hace responsable de ninguna de las consecuencias del uso de este material. 	<p>NOTA</p> <ul style="list-style-type: none"> ■ A instalação, utilização e manutenção do equipamento eléctrico devem ser efectuadas exclusivamente por pessoal qualificado. ■ A Schneider Electric não assume qualquer responsabilidade pelas consequências resultantes da utilização deste material. 	<p>ОБРАТИТЕ ВНИМАНИЕ</p> <ul style="list-style-type: none"> ■ Установка, эксплуатация, ремонт и обслуживание электрического оборудования может выполняться только квалифицированными электриками. ■ Компания Schneider Electric не несет никакой ответственности за любые возможные последствия использования данной 	<p>请注意</p> <ul style="list-style-type: none"> ■ 电气设备的安装、操作、维修和维护工作仅限于合格人员 执行。 ■ Schneider Electric 不承担由于使用本资料所引起的任何后果。
---	---	---	---

⚠️ ⚠️ PELIGRO / PERIGO / ОПАСНОСТЬ / 危險

<p>PELIGRO DE DESCARGA ELÉCTRICA, EXPLOSIÓN O ARCO ELÉCTRICO</p> <ul style="list-style-type: none"> ■ Utilice el equipo de protección personal (PPE) adecuado y siga las recomendaciones para el trabajo seguro con dispositivos eléctricos. Consulte NFPA 70E, CSA Z462 o la norma local equivalente. ■ Solo el personal de electricidad cualificado podrá instalar, programar y realizar el mantenimiento del equipo. ■ Desconecte toda la alimentación de este equipo antes de trabajar en él o en su interior. Bloquee la aparatamiento eléctrica en la posición de aislamiento. ■ Utilice siempre un dispositivo de detección de tensión de capacidad adecuada para confirmar la ausencia de alimentación eléctrica. ■ Instale barreras de seguridad y coloque un cartel de peligro. ■ Vuelva a colocar todos los dispositivos, las puertas y las tapas antes de conectar la alimentación de este equipo. <p>El incumplimiento de estas instrucciones podrá causar la muerte o lesiones serias.</p>	<p>PERIGO DE CHOQUE ELÉCTRICO, EXPLOSAO OU ARCO ELÉCTRICO</p> <ul style="list-style-type: none"> ■ Utilize equipamento de protecção pessoal (PPE) e siga os métodos de segurança eléctrica. Consulte NFPA 70E, CSA Z462 ou o equivalente local. ■ A instalação e manutenção deste equipamento só devem ser efectuadas por electricistas qualificados. ■ Desligue todas as fontes de alimentação deste equipamento antes de trabalhar no equipamento ou no seu interior. Bloquee a placa de distribuição na posição isolada. ■ Utilize sempre um dispositivo de detecção da tensão nominal adequada para confirmar se a alimentação está desligada. ■ Instale barreiras de segurança e apresente um sinal de perigo. ■ Substitua todos os dispositivos, portas e tampas antes de ligar a alimentação deste equipamento. <p>A não observância destas instruções resultará em morte, ou ferimentos graves.</p>	<p>ОПАСНОСТЬ ВЗРЫВА, ВСПЫШКИ ДУГИ ИЛИ ПОРАЖЕНИЯ ЭЛЕКТРИЧЕСКИМ ТОКОМ</p> <ul style="list-style-type: none"> ■ Используйте подходящие средства индивидуальной защиты (СИЗ) и соблюдайте технику безопасности при электротехнических работах. См. NFPA 70E, CSA Z462 или эквивалентные местные требования. ■ Это оборудование могут устанавливать и обслуживать только квалифицированные электрики. ■ Отключите питание до начала работ снаружи или внутри данного оборудования. Переведите распределительное устройство в выключенное положение. ■ Всегда убеждайтесь в том, что питание отключено, с помощью устройства измерения напряжения соответствующего диапазона. ■ Установите защитные ограждения и предупреждающий знак. ■ Перед включением питания данного оборудования установите на место все устройства, дверцы и крышки. <p>Несоблюдение этих инструкций приведет к смерти или серьезной травме.</p>	<p>电击、爆炸或电弧闪光危险</p> <ul style="list-style-type: none"> ■ 采用适当的个人防护设备 (PPE) 并遵循电气作业安全守则。请参阅 NFPA 70E, CSA Z462 或当地对应的标准。 ■ 只有具备相应资质的电气人员才能安装和维修该设备。 ■ 在该设备表面或内部工作之前, 请关闭设备的全部电源。将开关锁定在隔离位置。 ■ 确保使用合适的额定电压传感器确认电源已关闭。 ■ 安装安全栅并显示危险标志。 ■ 在给设备供电之前, 更换所有的设备, 门框, 盖板。 <p>不遵循上述说明将导致人员伤亡。</p>
--	---	---	---

**Manufacturing date / Date de fabrication / Herstellungsdatum / Data di fabbricazione /
Fecha de fabricación / Data de fabrico / Дата производства / 制造日期**

<p>The product's manufacture date is coded PP-YYYY-Www-D, where:</p> <ul style="list-style-type: none"> ■ PP: plant code ■ YYYY: year of manufacture ■ Www: week of manufacture ■ D: weekday of manufacture (Monday = 1) <p>Eg: 7Q-2014-W19-3 = product manufactured at plant 7Q on Wednesday 7 May 2014.</p>	<p>La date de fabrication du produit est codée PP-YYYY-Www-D, avec:</p> <ul style="list-style-type: none"> ■ PP: code usine ■ YYYY: année de fabrication ■ Www: semaine de fabrication ■ D: jour de fabrication dans la semaine (lundi = 1) <p>Ex: 7Q-2014-W19-3 = produit fabriqué le mercredi 7 mai 2014 par l'usine 7Q.</p>	<p>Das Herstellungsdatum des Produkts ist folgendermaßen codiert: PP-YYYY-Www-D. Wobei:</p> <ul style="list-style-type: none"> ■ PP: Werkscode ■ YYYY: Herstellungsjahr ■ Www: Herstellungswoche ■ D: Herstellungstag (Montag = 1) <p>Z. B: 7Q-2014-W19-3 = ein Produkt, das in Werk 7Q, am Mittwoch den 7 Mai, im Jahr 2014 gefertigt wurde.</p>	<p>La data di fabbricazione del prodotto è indicata con il codice PP-YYYY-Www-D, dove:</p> <ul style="list-style-type: none"> ■ PP: codice stabilimento ■ YYYY: anno di fabbricazione ■ Www: settimana di fabbricazione ■ D: giorno della settimana in cui il prodotto è stato fabbricato (lunedì = 1) <p>Ad es: 7Q-2014-W19-3 = prodotto fabbricato presso lo stabilimento 7Q mercoledì 7 maggio 2014.</p>
<p>La fecha de fabricación del producto está codificada PP-YYYY-Www-D, donde:</p> <ul style="list-style-type: none"> ■ PP: código de la planta ■ YYYY: año de fabricación ■ Www: semana de fabricación ■ D: día de la semana de fabricación (lunes = 1) <p>Ej: 7Q-2014-W19-3 = producto fabricado en la planta 7Q el miércoles 7 de mayo de 2014.</p>	<p>A data de fabrico do produto está sob a forma de código PP-YYYY-Www-D, onde:</p> <ul style="list-style-type: none"> ■ PP: código da fábrica ■ YYYY: ano de fabrico ■ Www: semana de fabrico ■ D: dia da semana de fabrico (Segunda-feira = 1) <p>Ex: 7Q-2014-W19-3 = produto fabricado na fábrica 7Q na Quarta-feira 7 de Maio de 2014.</p>	<p>Дата производства продукта закодирована в формате PP-YYYY-Www-D, где:</p> <ul style="list-style-type: none"> ■ PP: код завода ■ YYYY: год производства ■ Www: неделя производства ■ D: день недели, когда был произведен продукт (понедельник = 1) <p>Пример: 7Q-2014-W19-3 = продукт произведен на заводе 7Q в среду, 7 мая 2014 года.</p>	<p>产品制造日期采用如下代码 PP-YYYY-Www-D, 其中:</p> <ul style="list-style-type: none"> ■ PP: 工厂代码 ■ YYYY: 制造年份 ■ Www: 第几周制造 ■ D: 星期几制造 (星期一 = 1) <p>例如: 7Q-2014-W19-3 = 产品于 2014 年 5 月 7 日星期三 在 7Q 工厂制造。</p>

Dimensions and installation / Dimensions et installation / Abmessungen und Installation /
Dimensioni e installazione / Dimensiones e instalación / Dimensões e instalação / Размеры и монтаж /
尺寸与安装

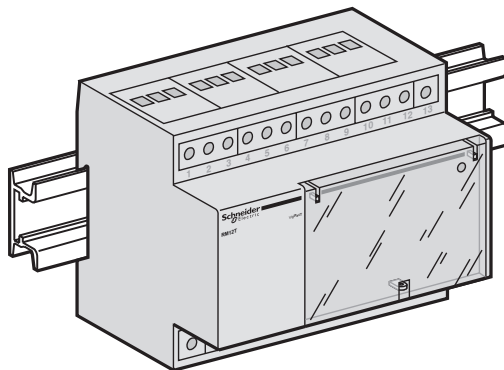
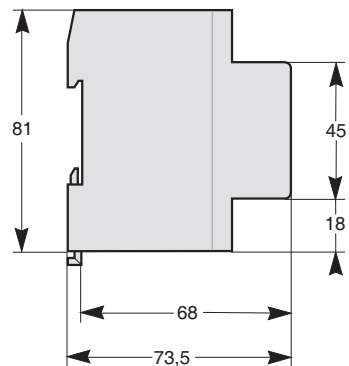
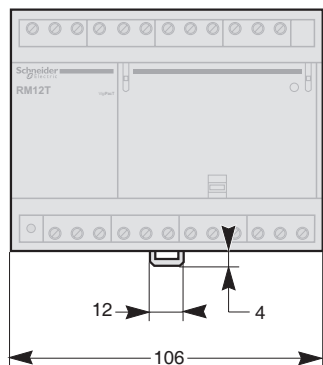

DB124924

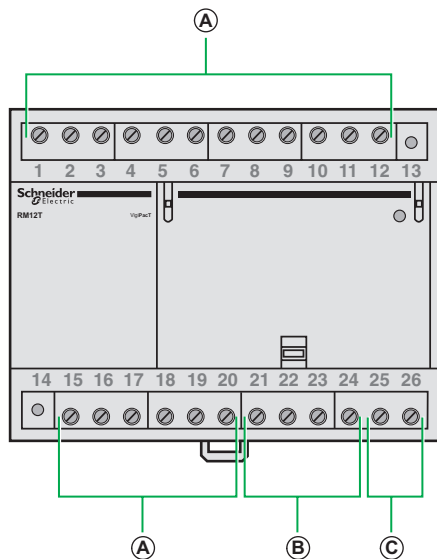

Ⓐ	1.5...2.5 mm ²
Ⓑ	0.75...2.5 mm ² , 2 twisted pairs
Ⓒ	0.75...2.5 mm ²

- (EN)** A Terminal blocks to connect up to 12 sensors. (Consult the VigiPacT catalogue for list of compatible sensors)
 B Terminal block to connect the RMH relay
 C Power supply terminal block
- (FR)** A Borniers pour la connexion de 12 capteurs maximum. (La liste des capteurs compatibles est fournie dans le catalogue VigiPacT)
 B Bornier pour la connexion du relais RMH
 C Bornier d'alimentation
- (DE)** A Klemmenleisten für den Anschluss von bis zu 12 Sensoren. (Im VigiPacT-Katalog finden Sie die Liste der kompatiblen Sensoren.)
 B Klemmenleiste für den Anschluss des RMH-Relais
 C Klemmenleiste der Spannungsversorgung
- (IT)** A Morsettiere per il collegamento di max 12 sensori. (Consultare il catalogo VigiPacT per un elenco dei sensori compatibili)
 B Morsettiere per il collegamento del relè RMH
 C Morsettiere per il collegamento dell'alimentazione
- (ES)** A Bloques de terminal para conectar hasta 12 sensores. (consulte el catálogo de VigiPacT para obtener una lista de los sensores compatibles)
 B Bloque de terminales en el que se conectará el relé de RMH
 C Bloque de terminales de la fuente de alimentación
- (PT)** A Blocos de terminais para ligar, no máximo, 12 sensores. (Consulte o catálogo da VigiPacT para obter uma lista dos sensores compatíveis)
 B Bloco de terminais para ligar o relé RMH
 C Bloco de terminais da fonte de alimentação
- (RU)** A Клеммные колодки для подключения до 12 датчиков. (Список совместимых датчиков см. в каталоге VigiPacT)
 B Клеммная колодка для подключения реле RMH
 C Клеммная колодка электропитания
- (ZH)** A 用于连接最多 12 个传感器的端子板。(查询 VigiPacT 目录获取兼容传感器的列表)
 B 用于连接 RMH 继电器的端子
 C 电源端子板

Wiring diagram / Schéma de câblage / Verdrahtungsplan / Schema di cablaggio / Diagrama de cableado / Diagrama de cablagem / Монтажная схема электропроводки / 接线图

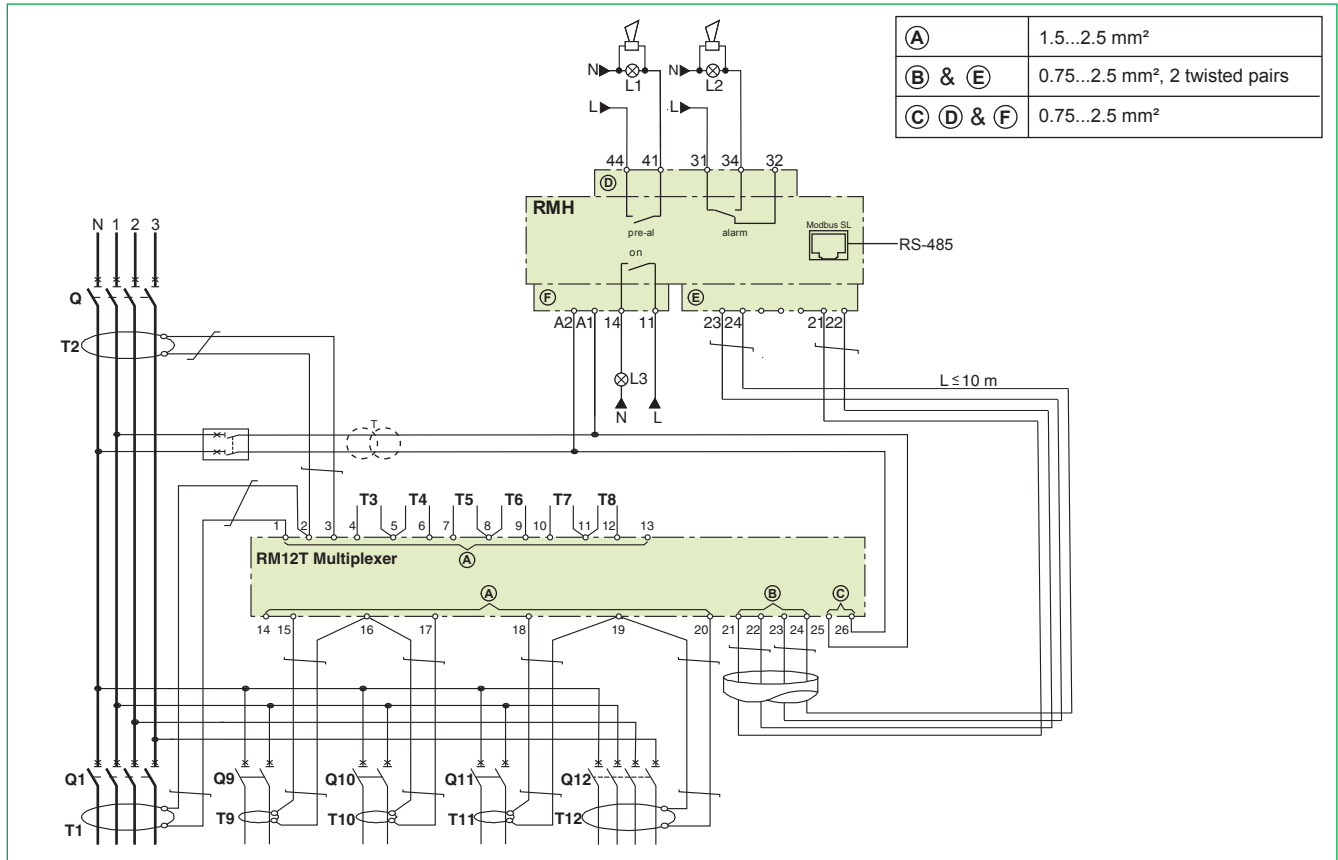

Technical data / Données techniques / Technische Daten / Dati tecnici / Especificaciones técnicas / Dados técnicos / Технические данные / 技术数据

<p>(EN) ■ Operating temperature: -25° C to +55° C</p> <p>■ Storage temperature: -55° C to +85° C</p> <p>■ Current measurement range: 15 mA to 60 A</p> <p>■ Type of network to monitor: <1000 V AC; 50 Hz, 60 Hz, and 400 Hz</p> <p>■ Power supply: 220/240 V AC -15 % / +10 %</p>	<p>(FR) ■ Température d'exploitation: -25° C à +55° C</p> <p>■ Température de stockage: -55° C à +85° C</p> <p>■ Plage de mesure d'intensité: 15 mA à 60 A</p> <p>■ Type de réseau à surveiller: <1000 V CA; 50 Hz, 60 Hz et 400 Hz</p> <p>■ Alimentation: 220/240 V CA avec -15 % / +10 %</p>	<p>(DE) ■ Betriebstemperatur: -25° C bis +55° C</p> <p>■ Lagertemperatur: -55° C bis +85° C</p> <p>■ Strommessbereich: 15 mA bis 60 A</p> <p>■ Typ des zu überwachenden Netzwerks: <1000 V AC / 50 Hz, 60 Hz und 400 Hz</p> <p>■ Spannungsversorgung: 220/240 V AC – -15 % / +10 %</p>	<p>(IT) ■ Temperatura di funzionamento: da -25° C a +55° C</p> <p>■ Temperatura di immagazzinamento: da -55° C a +85° C</p> <p>■ Intervallo di misurazione corrente: da 15 mA a 60 A</p> <p>■ Tipo di rete da controllare: <1000 V CA.; 50 Hz, 60 Hz e 400 Hz</p> <p>■ Alimentazione: 220-240 V CA. -15 % / +10 %</p>
<p>(ES) ■ Temperatura de funcionamiento: de -25° C a +55° C</p> <p>■ Temperatura de almacenamiento: de -55° C a +85° C</p> <p>■ Rango de medición de corriente: de 15 mA a 60 A</p> <p>■ Tipo de red que se monitorizará: <1.000 V CA; 50 Hz, 60 Hz y 400 Hz</p> <p>■ Fuente de alimentación: 220/240 V CA -15 % / +10 %</p>	<p>(PT) ■ Temperatura de funcionamento: -25° C a +55° C</p> <p>■ Temperatura de armazenamento: -55° C a +85° C</p> <p>■ Intervalo de medição da corrente: 15 mA a 60 A</p> <p>■ Tipo de rede a monitorizar: <1000 V CA; 50 Hz, 60 Hz e 400 Hz</p> <p>■ Fonte de alimentação: 220/240 V CA -15 % / +10 %</p>	<p>(RU) ■ Рабочая температура: от -25° C до +55° C</p> <p>■ Температура хранения: от -55° C до +85° C</p> <p>■ Диапазон измерения тока: от 15 mA до 60 A</p> <p>■ Тип контролируемой сети: <1000 В перем. тока; 50 Гц, 60 Гц и 400 Гц</p> <p>■ Электропитание: 220/240 В перем. тока –15 % / +10 %</p>	<p>(ZH) ■ 工作温度: -25° C 至 +55° C</p> <p>■ 存储温度: -55° C 至 +85° C</p> <p>■ 当前量程: 15 mA 至 60 A</p> <p>■ 被监控网络的类型: <1000 V AC; 50 Hz、60 Hz 和 400 Hz</p> <p>■ 电源: 220/240 V AC -15 % / +10 %</p>

Schneider Electric Industries SAS
35 rue Joseph Monier
CS 30323
F - 92506 Rueil Malmaison Cedex
www.se.com

Schneider Electric Limited
Stafford Park 5
Telford, TF3 3BL
United Kingdom
www.se.com/uk



**Уполномоченный поставщик в РФ:
АО «Шнейдер Электрик»**
Адрес: 127018, г. Москва, ул.
Двинцев, д. 12, корп. 1,
тел. +7 (495) 777 99 88,
факс: +7 (495) 777 99 94, 8-800-200-6446
www.se.com/ru



Printed on
recycled paper.