

**Compact
INV 250
NSX 250**

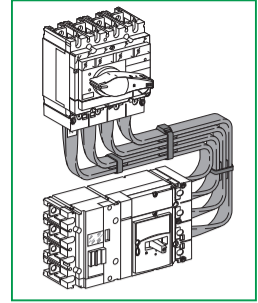

04445188AA-03

PLEASE NOTE
 ■ Electrical equipment should be installed, operated, serviced, and maintained only by qualified personnel.
 ■ No responsibility is assumed by Schneider Electric for any consequences arising out of the use of this material.

REMARQUE IMPORTANTE
 ■ L'installation, l'utilisation, la réparation et la maintenance des équipements électriques doivent être assurés uniquement par du personnel qualifié.
 ■ Schneider Electric décline toute responsabilité quant aux conséquences de l'utilisation de ce matériel.

TENGA EN CUENTA
 ■ La instalación, manejo, puesta en servicio y mantenimiento de equipos eléctricos deberán ser realizados sólo por personal cualificado.
 ■ Schneider Electric no se hace responsable de ninguna de las consecuencias del uso de este material.

Schneider Electric Industries SAS
 35, rue Joseph Monier
 CS 30323
 F - 92506 Rueil Malmaison Cedex

www.schneider-electric.com

 © 2018 Schneider Electric. All rights reserved.

x 4	
x 4	Ø3 x 12
x 2	Ø3 x 16

Pozidriv n° 2
ou plat /
slotted screwdriver

15 N.m

1

2

1 x Ø3 x 16
1 N.m

2 x Ø3 x 12
1,2 N.m

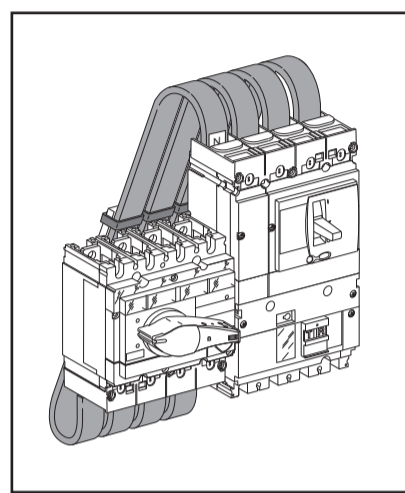

x 4	
x 4	Ø3 x 12
x 2	Ø3 x 16

Pozidriv n° 2
ou plat /
slotted screwdriver

15 N.m

1

2

2 x Ø3 x 12
1,2 N.m

1 x Ø3 x 16
1 N.m

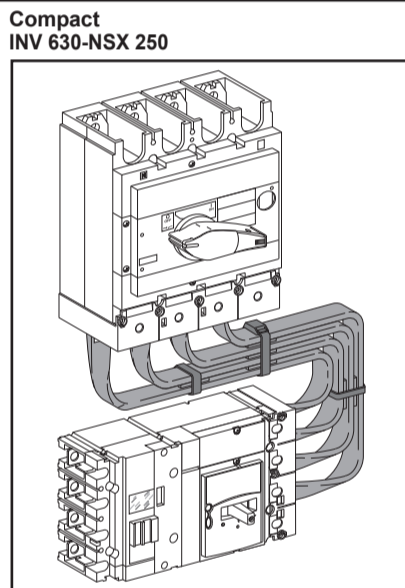

x 4	
x 4	Ø3 x 12
x 2	Ø3 x 16

Pozidriv n° 2
ou plat /
slotted screwdriver

50 N.m

1

2

1 x Ø3 x 16
1 N.m

2 x Ø3 x 12
1,2 N.m

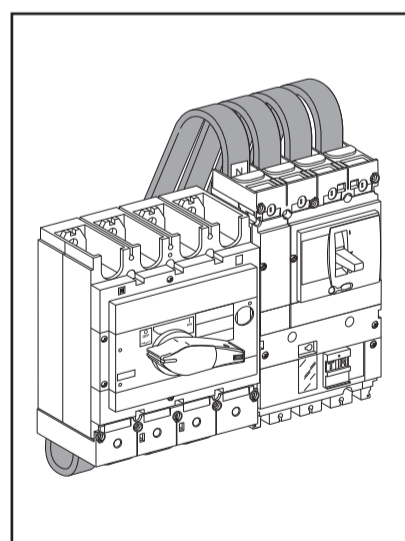

x 4	
x 4	Ø3 x 12
x 2	Ø3 x 16

Pozidriv n° 2
ou plat /
slotted screwdriver

15 N.m

1

2

2 x Ø3 x 12
1,2 N.m

1 x Ø3 x 16
1 N.m

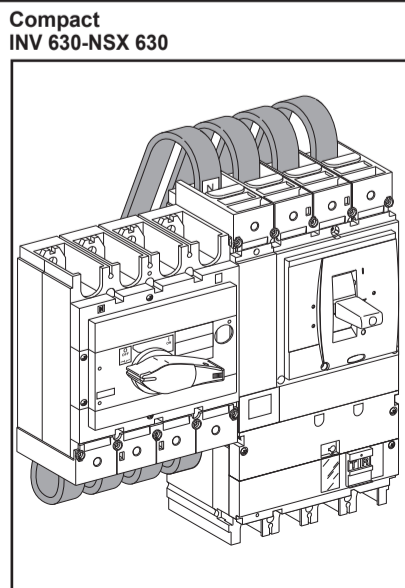

x 4	
x 4	Ø3 x 12
x 2	Ø3 x 16

Pozidriv n° 2
ou plat /
slotted screwdriver

50 N.m

1

2

2 x Ø3 x 12
1,2 N.m

1 x Ø3 x 16
1 N.m