



**DOCIA RANGE : Traps for tiled flooring**  
**PVC trap with 15 x 15 grid , horizontal outlet**



**SICAX15HNC – SICAX15HC – SICAX15IH – SICAX15HNP**

**FUNCTION :**

These traps are aimed at draining water from tiled floorings :

- They can be used on public or private facilities, especially in dwellings and hospitals, retirement homes, students homes, technical facilities, dressing-rooms, etc.
- They guarantee a perfect waterproofing, whatever the situation (under screed waterproofing, or under tile waterproofing).
- They adapt to any height of screed and tile.

Pictures	Codes Nr	Designation	Class	Membrane	Grid	Picture grid
	SICAX15HNC	Trap with grid and frame 304 stainless	K3	Yes	Square design	
	SICAX15HC	Trap with grid and frame 304 stainless	K3	No	Square design	
	SICAX15IH	Trap with frame 304 stainless	K3	No	No	At choice
	SICAX15HNP	Trap with grid and frame white PVC	K3	Yes	White PVC	

**DESCRIPTION :**

These traps are composed of :

- A floor trap in PVC, heat resistant.
- A clamp ring for waterproofing membrane with screws in stainless steel.
- A cuttable extension tube with a frame and 15 x15 grid.
- A waterproofing membrane, 36cm x 36cm (according to the versions).
- Horizontal outlet : Ø 50 male, and 40 Ø female .
- Flow rate : 0,8l/s .
- Water seal height : 50mm





**DOCIA RANGE : Traps for tiled flooring**  
**PVC trap with 15 x 15 grid, horizontal outlet**



**SICAX15HNC – SICAX15HC – SICAX15H – SICAX15HNP**

**ACCESSORIES :**

- Designer grids in 304 stainless steel, 15 x 15, tickness 2 mm :

GSICAX15IB

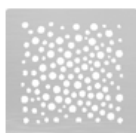

GSICAX15IA



GSICAX15IE



GSICAX15IL



GSICAX15IC

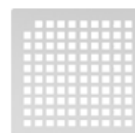

- Additional extension part (optional) : RALSIX



**INSTALLATION :**

- Prepare a Ø 250mm recess.
- Place and connect the soil pipe to the trap, with solvent welding.
- Make a slope (waterproofing under or above the screed).
- Depending on the screed or tile thickness, adjust the height of the extension tube (by cutting if needed), leaving the 12 mm necessary for the clipping (for particularly thick screeds, the additional extension part must be used).
- Clip the extension tube + frame + extension part on the trap.
- Put the tile and make the tiles joints.

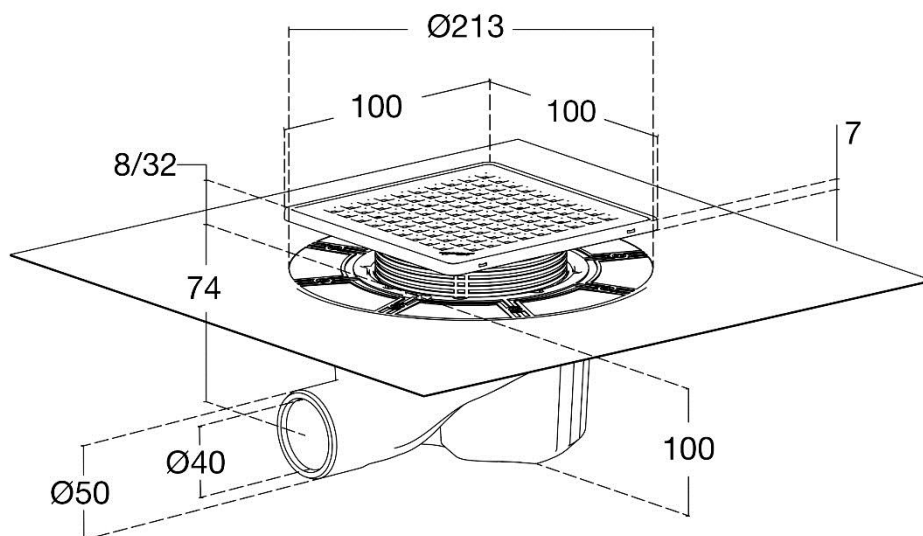

October 2017



*Nicoll*

Siège social : 37, rue Pierre & Marie Curie  
BP 10966 - 49309 Cholet Cedex  
Tel : 02 41 63 73 83  
Fax : 02 41 63 73 57  
Email: tech-com.nicoll@alifax.com

an *Alifax* company