

NH fuse-links gG 690VAC

double indicator/isolated gripping-lugs size 000, 00, 0, 1, 2, 3

LOW VOLTAGE IEC FUSES

IEC NH FUSE-LINKS



The NH system is classified among plug-in fuse systems and is composed of:

- fuse-base (possibly including terminal covers and phase barriers)
- fuse-link with blade contact
- fuse-link replacement device (LV HRC fuse puller)

Since the design of this system cannot guarantee non-interchangeability of rated current it must be handled by a qualified professional.

Type “gG” NH fuse-links are full range breaking capacity fuse-links and are used to protect cables and equipment. They can interrupt any current surge, from the lowest fusing current up to their breaking capacity, and so can be used alone as protection. They also protect electrical devices and industrial set-ups from the electrodynamic effects of very high short-circuit currents.

TECHNICAL DATA OVERVIEW

Ampere Range (A)	2 ... 425 A
Size per Standard	Sizes 000 to 3
Speed/Characteristic	gG
I.R. AC (IEC)	80 kA
Body Material	ceramic
Contact Materials	copper, silver-plated

FEATURES & BENEFITS

- Dimensions according to DIN 43 620 Parts 1 to 4
- Isolated metal gripping lugs (SGL)
- Double indicator
- Lead free contact blades
- 0% cadmium

APPLICATIONS

- gG: general purpose cable and line protection

STANDARDS

- VDE 0636 Part 201
- IEC 60269-1 and -2



NH fuse-links gG 690VAC

double indicator/isolated gripping-lugs size 000, 00, 0, 1, 2, 3

PRODUCT RANGE

Size 000 gG 690VAC isolated gripping-lugs

Catalog number	Item number	Rated voltage AC (IEC)	Rated voltage DC (IEC)	Rated current I _n	Power dissipation at I _n	Width	Weight	Package
NH000GG69V2-1	D229704	690 V	250 V	2 A	1.9 W	20.8 mm	0.14 kg	3
NH000GG69V4-1	E229705	690 V	250 V	4 A	1.5 W	20.8 mm	0.14 kg	3
NH000GG69V6-1	F229706	690 V	250 V	6 A	1.6 W	20.8 mm	0.14 kg	3
NH000GG69V10-1	H229708	690 V	250 V	10 A	1.1 W	20.8 mm	0.14 kg	3
NH000GG69V16-1	J229709	690 V	250 V	16 A	1.8 W	20.8 mm	0.14 kg	3
NH000GG69V20-1	K229710	690 V	250 V	20 A	2.3 W	20.8 mm	0.14 kg	3
NH000GG69V25-1	L229711	690 V	250 V	25 A	2.4 W	20.8 mm	0.14 kg	3
NH000GG69V32-1	M229712	690 V	250 V	32 A	3.1 W	20.8 mm	0.14 kg	3
NH000GG69V35-1	N229713	690 V	250 V	35 A	3 W	20.8 mm	0.14 kg	3
NH000GG69V40-1	P229714	690 V	250 V	40 A	3.7 W	20.8 mm	0.14 kg	3
NH000GG69V50-1	Q229715	690 V	250 V	50 A	4.1 W	20.8 mm	0.14 kg	3
NH000GG69V63-1	R229716	690 V	250 V	63 A	5.4 W	20.8 mm	0.14 kg	3
NH000GG69V80-1	S229717	690 V	250 V	80 A	6.5 W	20.8 mm	0.14 kg	3



NH00GG69V125-1

Size 00 gG 690VAC isolated gripping-lugs

Catalog number	Item number	Rated voltage AC (IEC)	Rated voltage DC (IEC)	Rated current I _n	Power dissipation at I _n	Width	Weight	Package
NH00GG69V35-1	V229719	690 V	250 V	35 A	3 W	29.5 mm	0.2 kg	3
NH00GG69V40-1	W229720	690 V	250 V	40 A	3.7 W	29.5 mm	0.2 kg	3
NH00GG69V50-1	X229721	690 V	250 V	50 A	4.1 W	29.5 mm	0.2 kg	3
NH00GG69V63-1	Y229722	690 V	250 V	63 A	5.6 W	29.5 mm	0.2 kg	3
NH00GG69V80-1	Z229723	690 V	250 V	80 A	6.8 W	29.5 mm	0.2 kg	3
NH00GG69V100-1	A229724	690 V	250 V	100 A	7.5 W	29.5 mm	0.2 kg	3
NH00GG69V125-1	B229725	690 V	250 V	125 A	10 W	29.5 mm	0.2 kg	3

Size 0 gG 690VAC isolated gripping-lugs

Catalog number	Item number	Rated voltage AC (IEC)	Rated voltage DC (IEC)	Rated current I _n	Power dissipation at I _n	Width	Weight	Package
NH0GG69V50-1	L229734	690 V	400 V	50 A	4.1 W	29.5 mm	0.25 kg	3
NH0GG69V63-1	M229735	690 V	400 V	63 A	6.6 W	29.5 mm	0.25 kg	3
NH0GG69V80-1	N229736	690 V	400 V	80 A	8 W	29.5 mm	0.25 kg	3
NH0GG69V100-1	P229737	690 V	400 V	100 A	9.4 W	29.5 mm	0.25 kg	3
NH0GG69V125-1	Q229738	690 V	400 V	125 A	11.8 W	29.5 mm	0.25 kg	3
NH0GG69V160-1	R229739	690 V	400 V	160 A	14.6 W	29.5 mm	0.25 kg	3

MERSEN reserves the right to change, update or correct, without notice, any information contained in this datasheet.

NH fuse-links gG 690VAC

double indicator/isolated gripping-lugs size 000, 00, 0, 1, 2, 3

PRODUCT RANGE

Size 1 gG 690VAC isolated gripping-lugs

Catalog number	Item number	Rated voltage AC (IEC)	Rated voltage DC (IEC)	Rated current I _n	Power dissipation at I _n	Width	Weight	Package
NH1GG69V16-1	S229740	690 V	400 V	16 A	1.8 W	29.5 mm	0.29 kg	1
NH1GG69V25-1	V229742	690 V	400 V	25 A	2.4 W	29.5 mm	0.29 kg	1
NH1GG69V32-1	W229743	690 V	400 V	32 A	3.1 W	29.5 mm	0.29 kg	1
NH1GG69V35-1	X229744	690 V	400 V	35 A	3 W	29.5 mm	0.29 kg	1
NH1GG69V40-1	Y229745	690 V	400 V	40 A	3.7 W	29.5 mm	0.29 kg	1
NH1GG69V50-1	Z229746	690 V	400 V	50 A	4.1 W	29.5 mm	0.29 kg	1
NH1GG69V63-1	A229747	690 V	400 V	63 A	6.6 W	29.5 mm	0.29 kg	1
NH1GG69V80-1	B229748	690 V	400 V	80 A	8 W	29.5 mm	0.29 kg	1
NH1GG69V100-1	C229749	690 V	400 V	100 A	9.4 W	29.5 mm	0.29 kg	1
NH1GG69V125-1	D229750	690 V	400 V	125 A	11.8 W	39.5 mm	0.42 kg	1
NH1GG69V160-1	E229751	690 V	400 V	160 A	14.6 W	39.5 mm	0.42 kg	1
NH1GG69V200-1	F229752	690 V	400 V	200 A	18 W	39.5 mm	0.42 kg	1
NH1GG69V224-1	G229753	690 V	-	224 A	19 W	39.5 mm	0.42 kg	1

Size 2 gG 690VAC isolated gripping-lugs

Catalog number	Item number	Rated voltage AC (IEC)	Rated current I _n	Power dissipation at I _n	Width	Weight	Package
NH2GG69V32-1	J229755	690 V	32 A	3.1 W	39.5 mm	0.43 kg	3
NH2GG69V35-1	K229756	690 V	35 A	3 W	39.5 mm	0.43 kg	3
NH2GG69V40-1	L229757	690 V	40 A	3.7 W	39.5 mm	0.43 kg	3
NH2GG69V50-1	M229758	690 V	50 A	4.1 W	39.5 mm	0.43 kg	3
NH2GG69V63-1	N229759	690 V	63 A	6.8 W	39.5 mm	0.43 kg	3
NH2GG69V80-1	P229760	690 V	80 A	8.3 W	39.5 mm	0.43 kg	3
NH2GG69V100-1	Q229761	690 V	100 A	10.7 W	39.5 mm	0.43 kg	3
NH2GG69V125-1	R229762	690 V	125 A	12.2 W	39.5 mm	0.43 kg	3
NH2GG69V160-1	S229763	690 V	160 A	15 W	39.5 mm	0.43 kg	3
NH2GG69V200-1	T229764	690 V	200 A	18.5 W	39.5 mm	0.43 kg	3
NH2GG69V224-1	V229765	690 V	224 A	19.2 W	39.5 mm	0.43 kg	3
NH2GG69V250-1	D233729	690 V	250 A	20.6 W	51 mm	0.64 kg	3
NH2GG69V300-1	X229767	690 V	300 A	21 W	51 mm	0.64 kg	3
NH2GG69V315-1	Y229768	690 V	315 A	25 W	51 mm	0.64 kg	3
NH2GG69V355-1	Z229769	690 V	355 A	31.5 W	51 mm	0.64 kg	3

Size 3 gG 690VAC isolated gripping-lugs

Catalog number	Item number	Rated voltage AC (IEC)	Rated current I _n	Power dissipation at I _n	Width	Weight	Package
NH3GG69V315-1	C229772	690 V	315 A	25 W	51 mm	0.65 kg	1
NH3GG69V355-1	D229773	690 V	355 A	32 W	51 mm	0.65 kg	1
NH3GG69V400-1	E229774	690 V	400 A	34 W	70 mm	1.05 kg	1
NH3GG69V425-1	F229775	690 V	425 A	34 W	70 mm	1.05 kg	1

TECHNICAL DATA

	Size 000	Size 00	Size 0	Size 1	Size 2	Size 3
Rated current	2 ... 80 A	35 ... 125 A	50 ... 160 A	16 ... 224 A	32 ... 355 A	315 ... 425 A
Rated breaking capacity AC	80 kA	80 kA	80 kA	80 kA	80 kA	80 kA
Rated voltage AC	690 V	690 V	690 V	690 V	690 V	690 V
Indication System	double indicator	double indicator	double indicator	double indicator	double indicator	double indicator
Width	21 mm	30 mm	30 mm	40 mm	52 mm	72 mm

NH fuse-links gG 690VAC

double indicator/isolated gripping-lugs size 000, 00, 0, 1, 2, 3

TIME CURRENT CHARACTERISTIC CURVES

Size 000

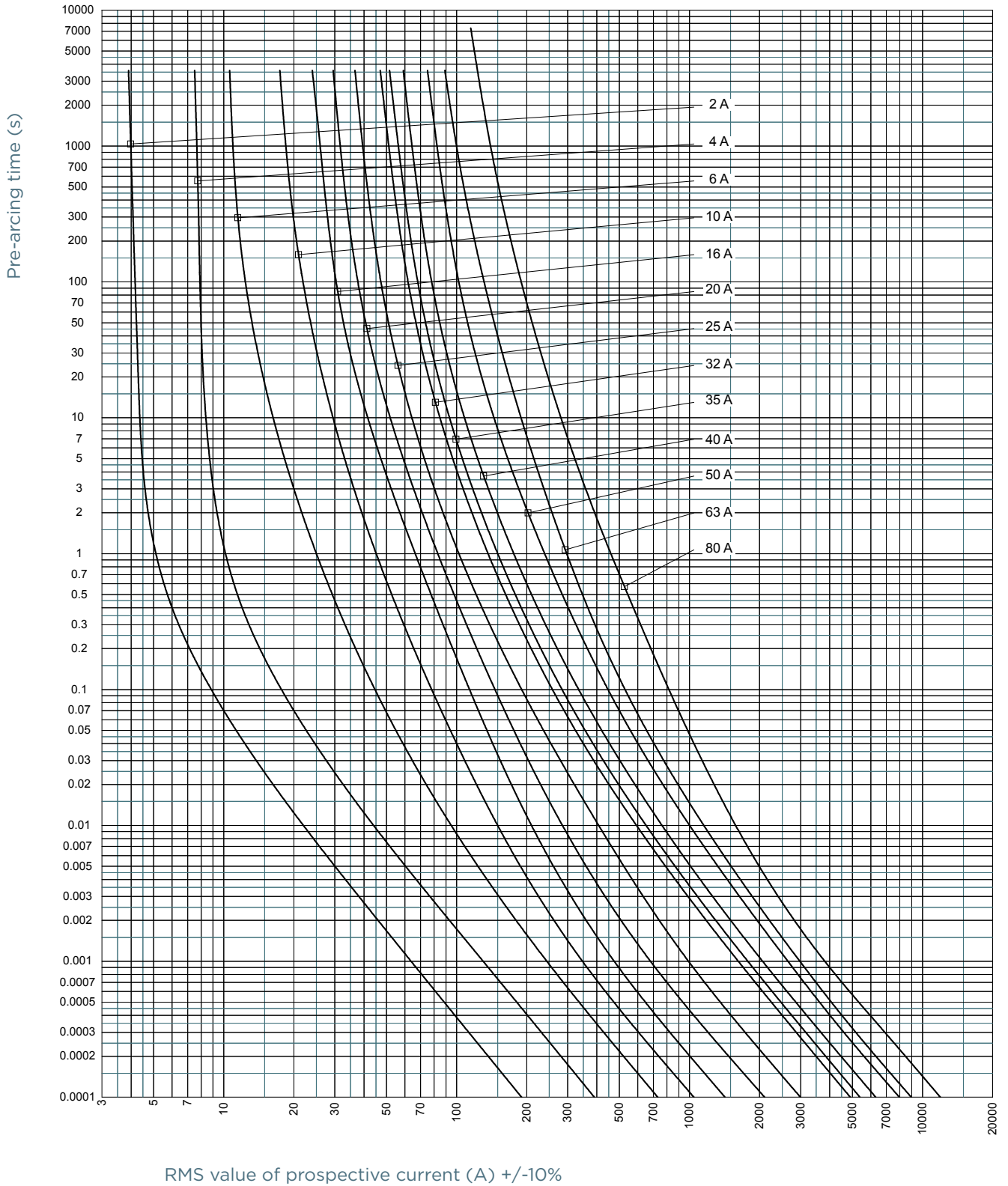

MERSEN reserves the right to change, update or correct, without notice, any information contained in this datasheet.

NH fuse-links gG 690VAC

double indicator/isolated gripping-lugs size 000, 00, 0, 1, 2, 3

TIME CURRENT CHARACTERISTIC CURVES

Size 00

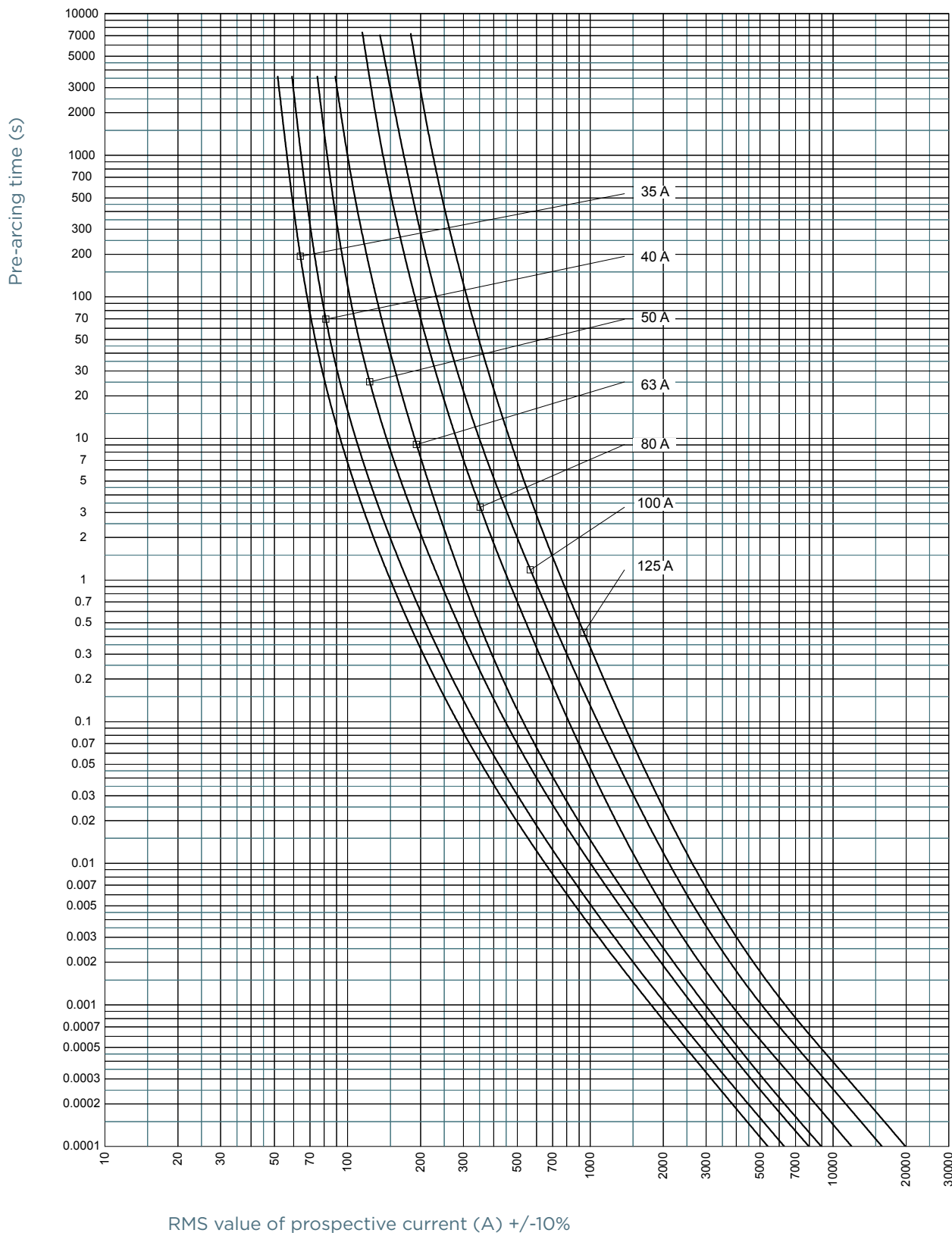

MERSEN reserves the right to change, update or correct, without notice, any information contained in this datasheet.

NH fuse-links gG 690VAC

double indicator/isolated gripping-lugs size 000, 00, 0, 1, 2, 3

TIME CURRENT CHARACTERISTIC CURVES

Size 0

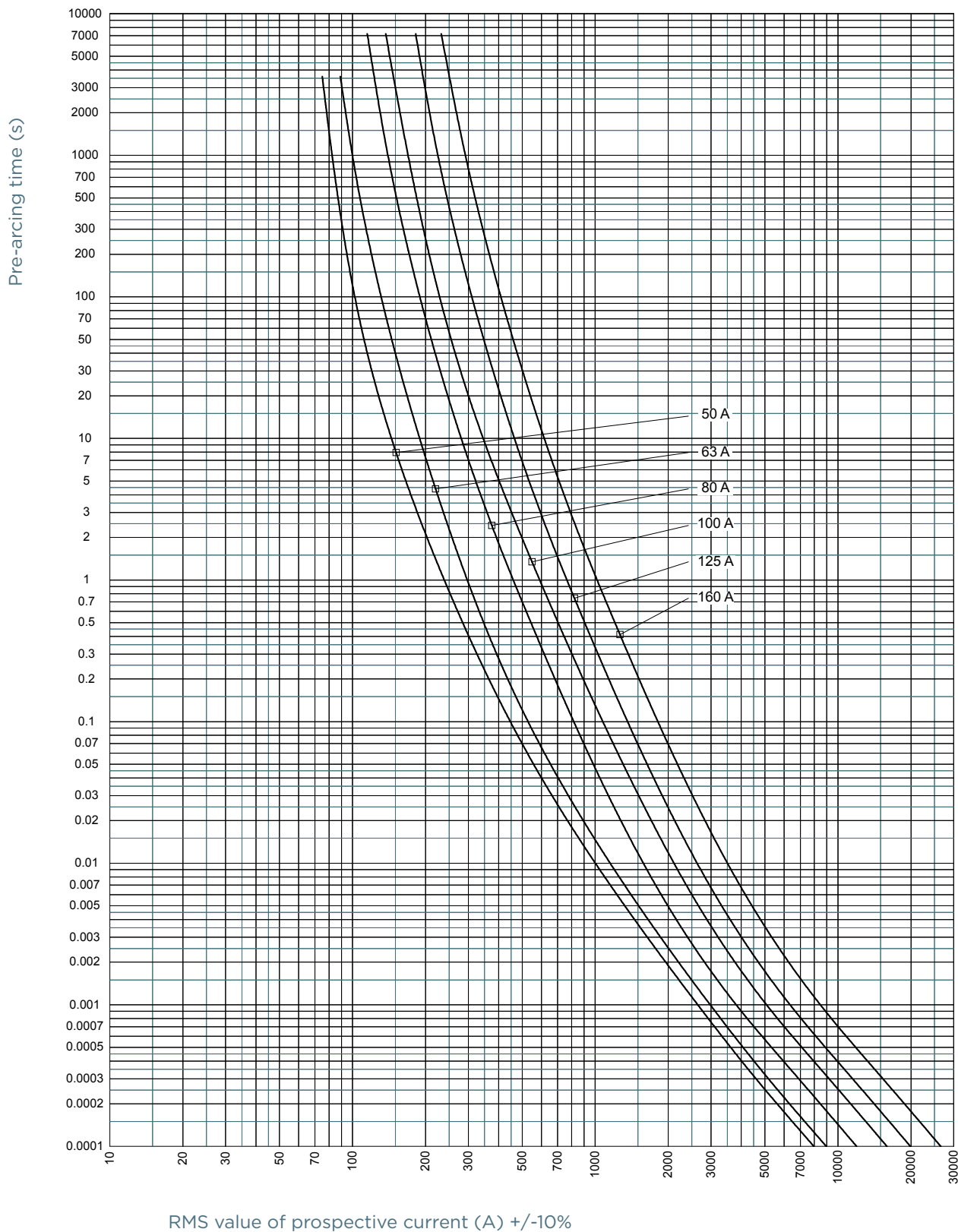

MERSEN reserves the right to change, update or correct, without notice, any information contained in this datasheet.

NH fuse-links gG 690VAC

double indicator/isolated gripping-lugs size 000, 00, 0, 1, 2, 3

TIME CURRENT CHARACTERISTIC CURVES

Size 1

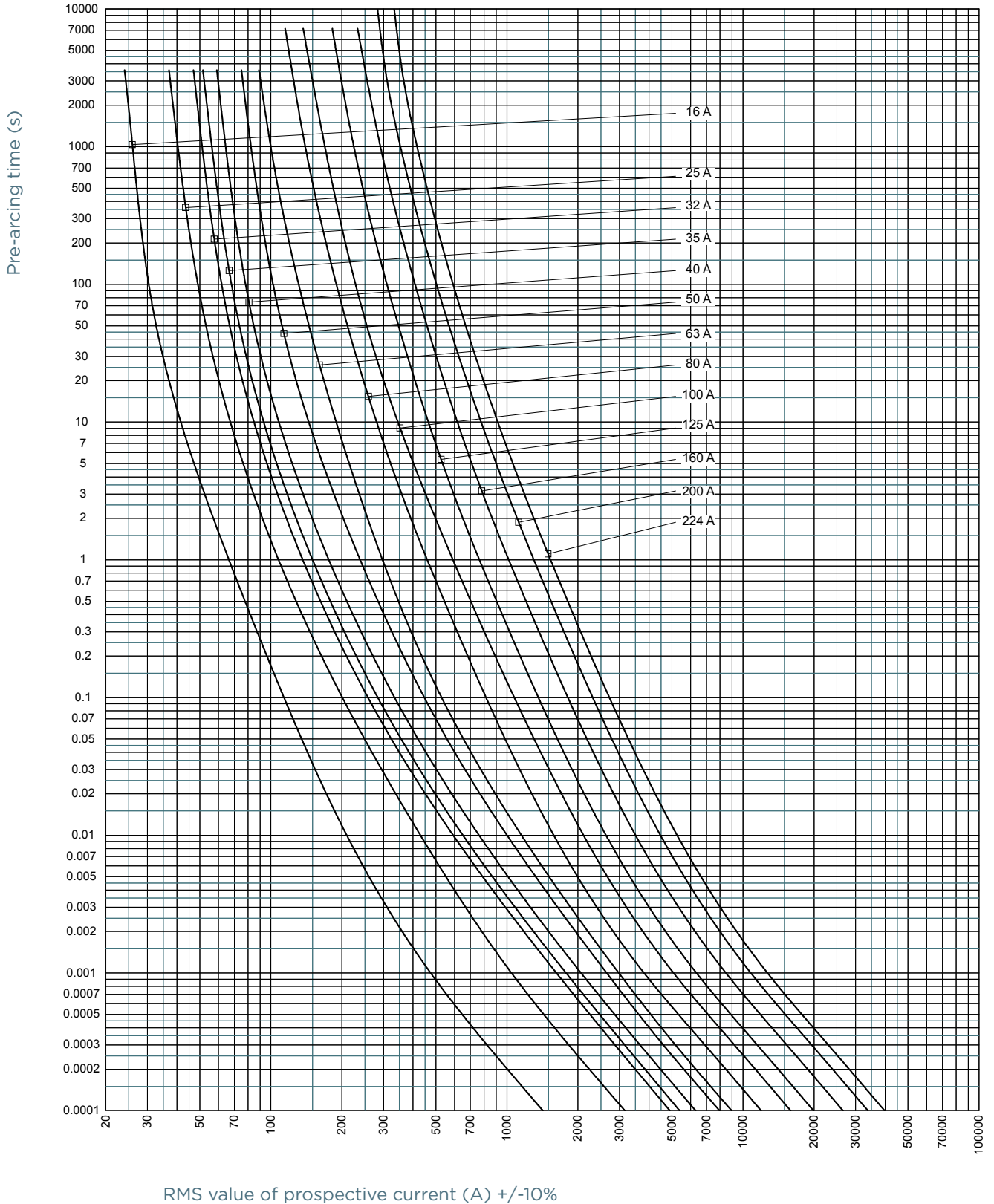

MERSEN reserves the right to change, update or correct, without notice, any information contained in this datasheet.

NH fuse-links gG 690VAC

double indicator/isolated gripping-lugs size 000, 00, 0, 1, 2, 3

TIME CURRENT CHARACTERISTIC CURVES

Size 2

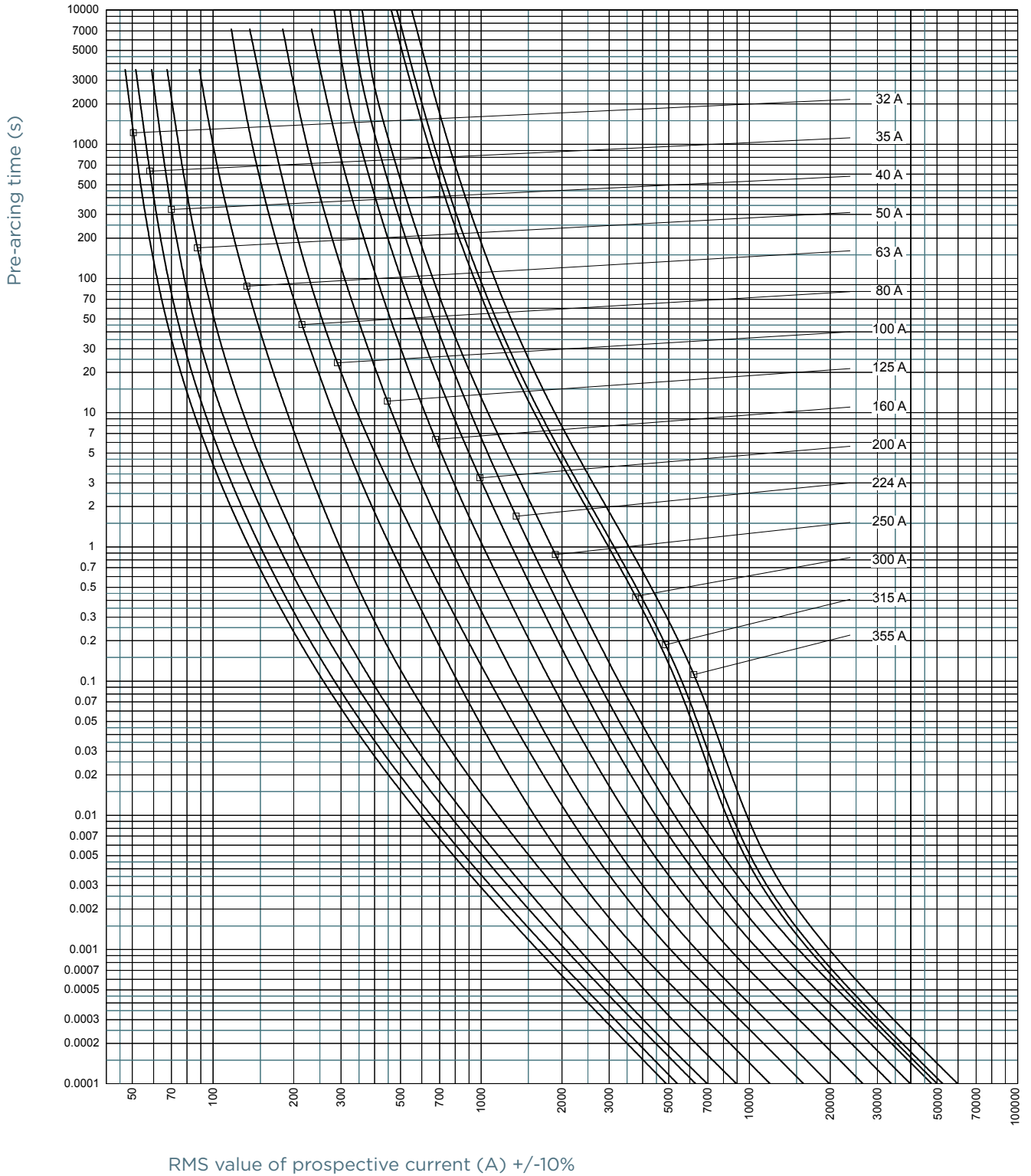

MERSEN reserves the right to change, update or correct, without notice, any information contained in this datasheet.

NH fuse-links gG 690VAC

double indicator/isolated gripping-lugs size 000, 00, 0, 1, 2, 3

TIME CURRENT CHARACTERISTIC CURVES

Size 3

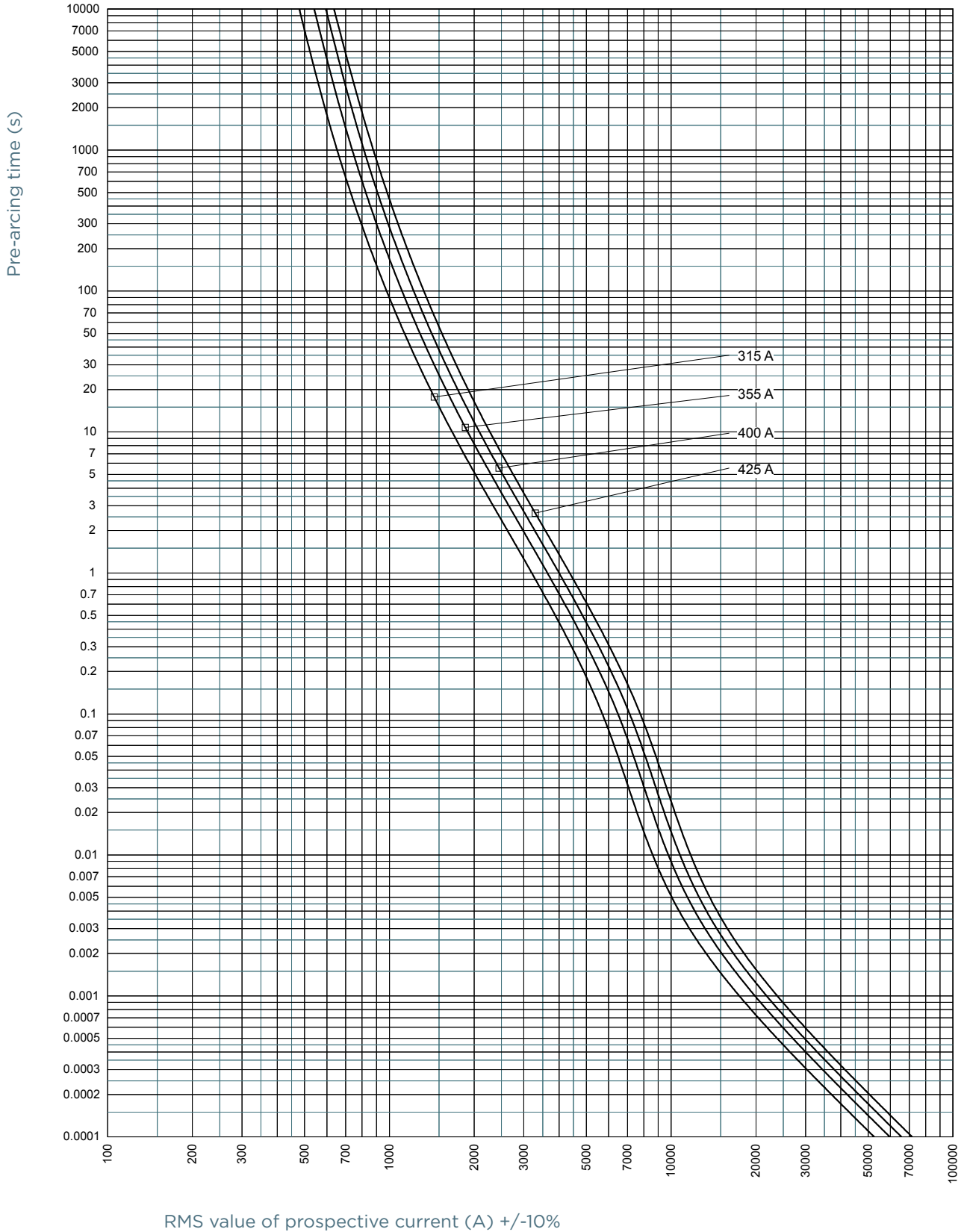

MERSEN reserves the right to change, update or correct, without notice, any information contained in this datasheet.

NH fuse-links gG 690VAC

double indicator/isolated gripping-lugs size 000, 00, 0, 1, 2, 3

CUT-OFF CURRENT CHARACTERISTIC

Size 000

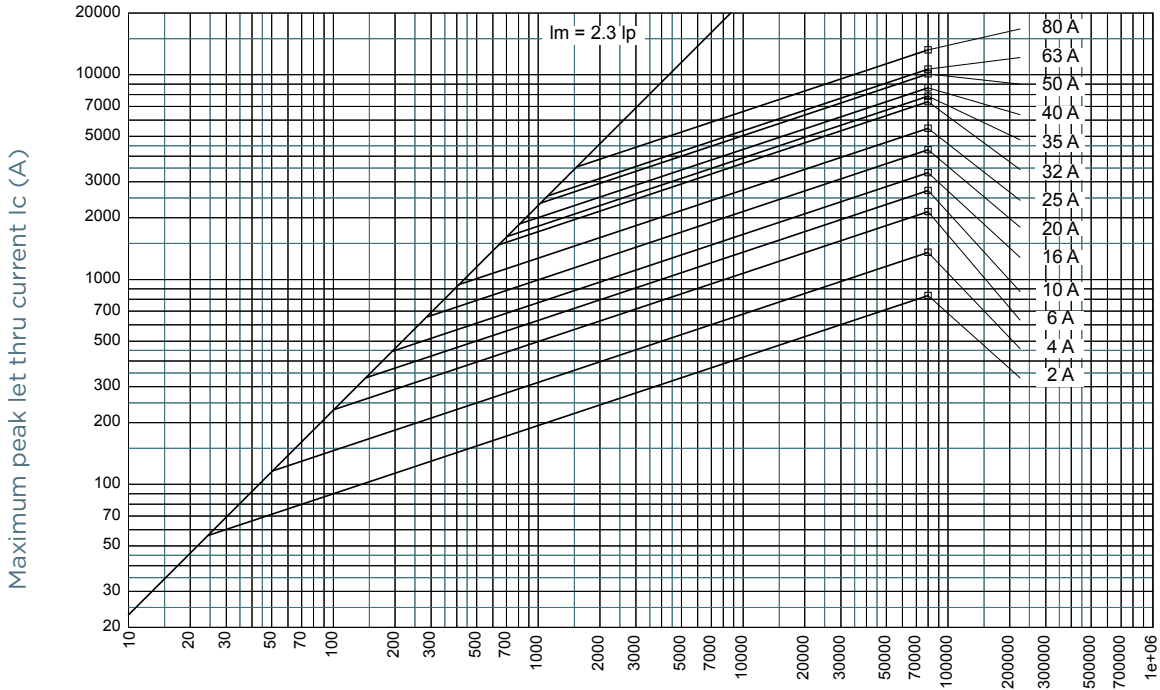

50 Hz RMS symmetrical prospective current I_p (A)

Size 00

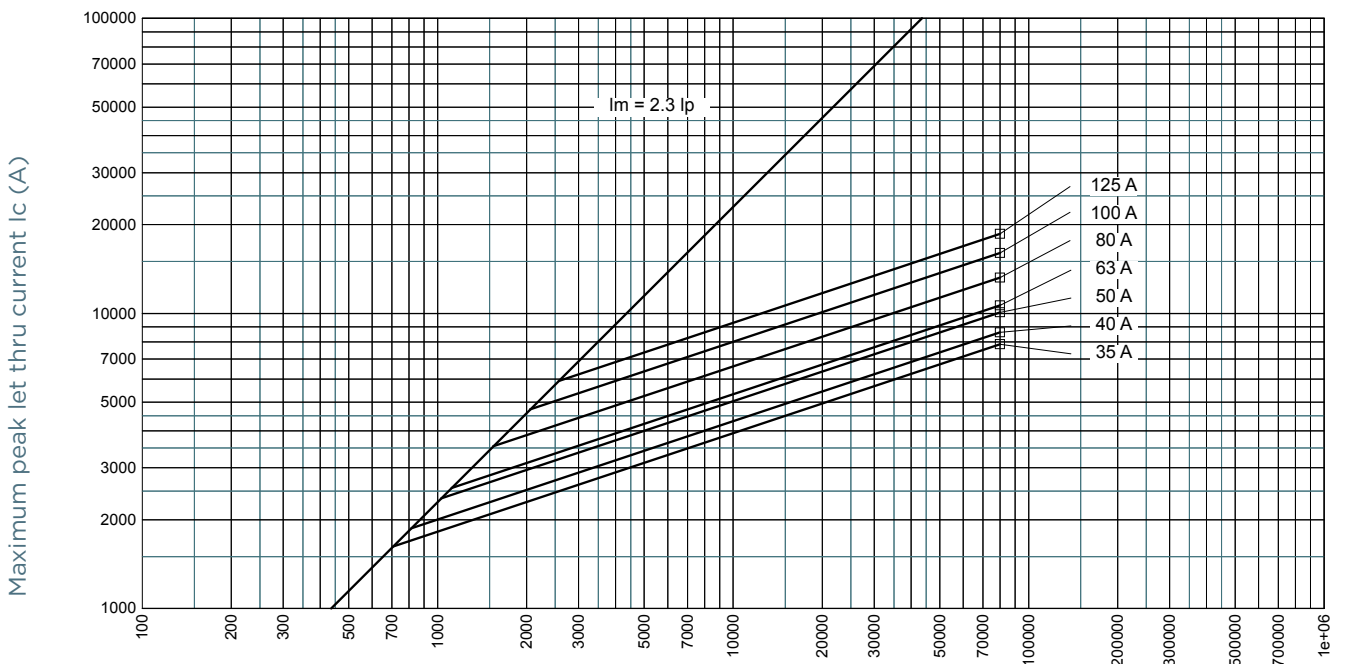

50 Hz RMS symmetrical prospective current I_p (A)

MERSEN reserves the right to change, update or correct, without notice, any information contained in this datasheet.

NH fuse-links gG 690VAC

double indicator/isolated gripping-lugs size 000, 00, 0, 1, 2, 3

CUT-OFF CURRENT CHARACTERISTIC

Size 0

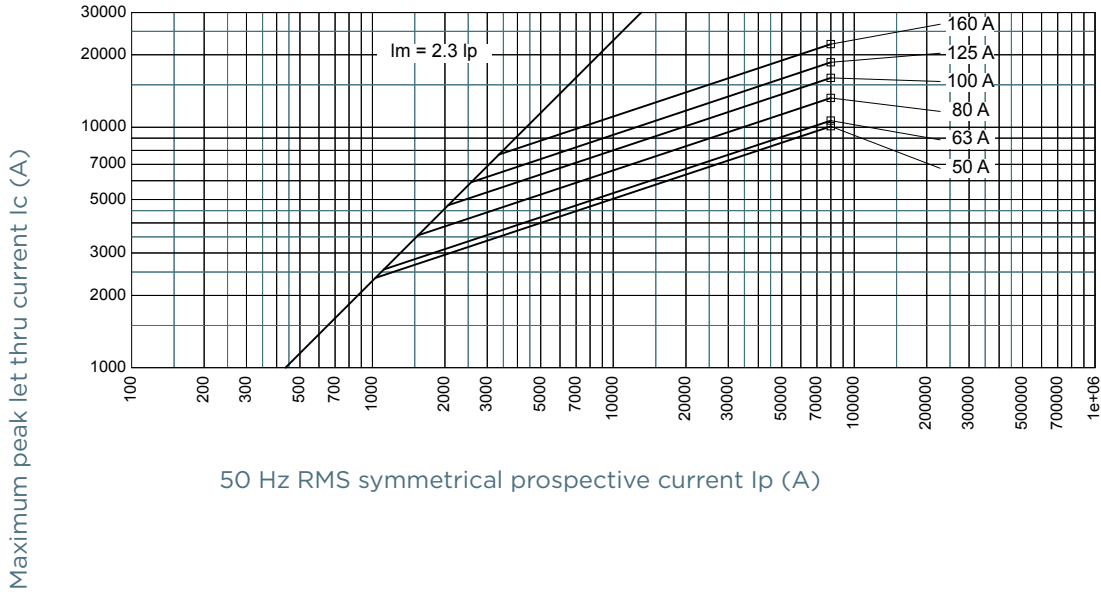

Size 1

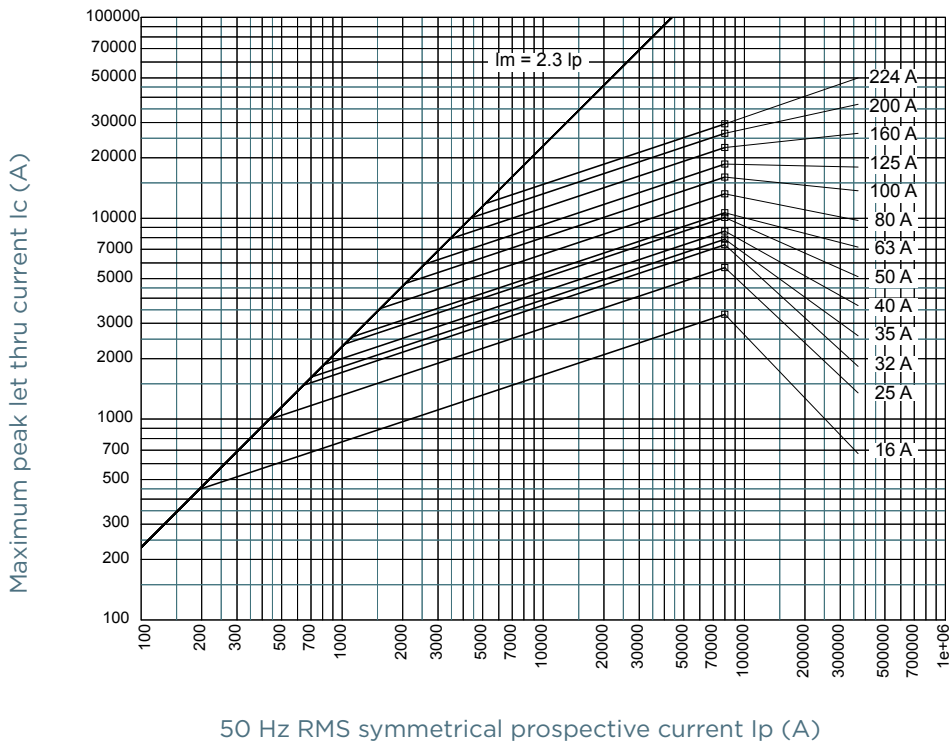

MERSEN reserves the right to change, update or correct, without notice, any information contained in this datasheet.

NH fuse-links gG 690VAC

double indicator/isolated gripping-lugs size 000, 00, 0, 1, 2, 3

CUT-OFF CURRENT CHARACTERISTIC

Size 2

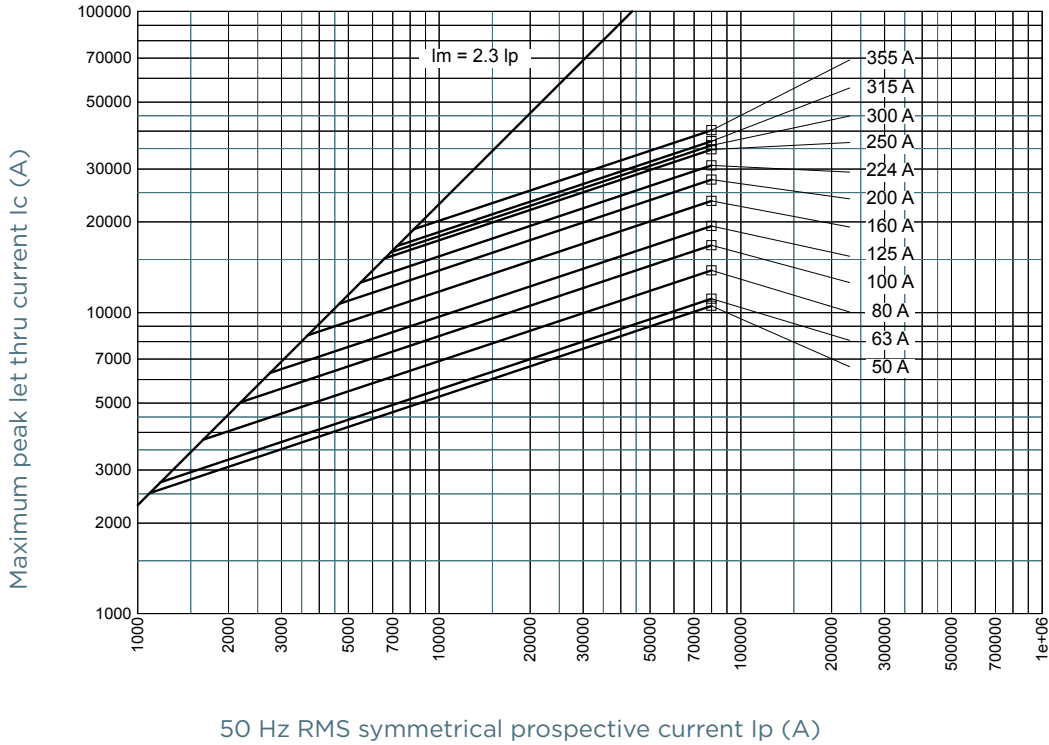

Size 3

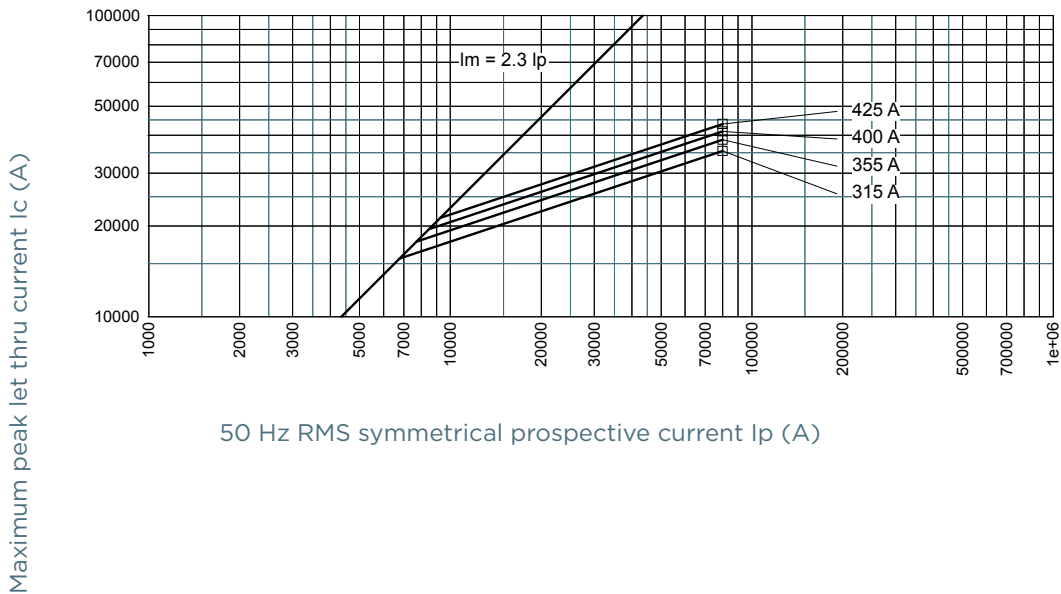

MERSEN reserves the right to change, update or correct, without notice, any information contained in this datasheet.

NH fuse-links gG 690VAC

double indicator/isolated gripping-lugs size 000, 00, 0, 1, 2, 3

PRE-ARCING AND OPERATING I²t CHARACTERISTICS

Size 000

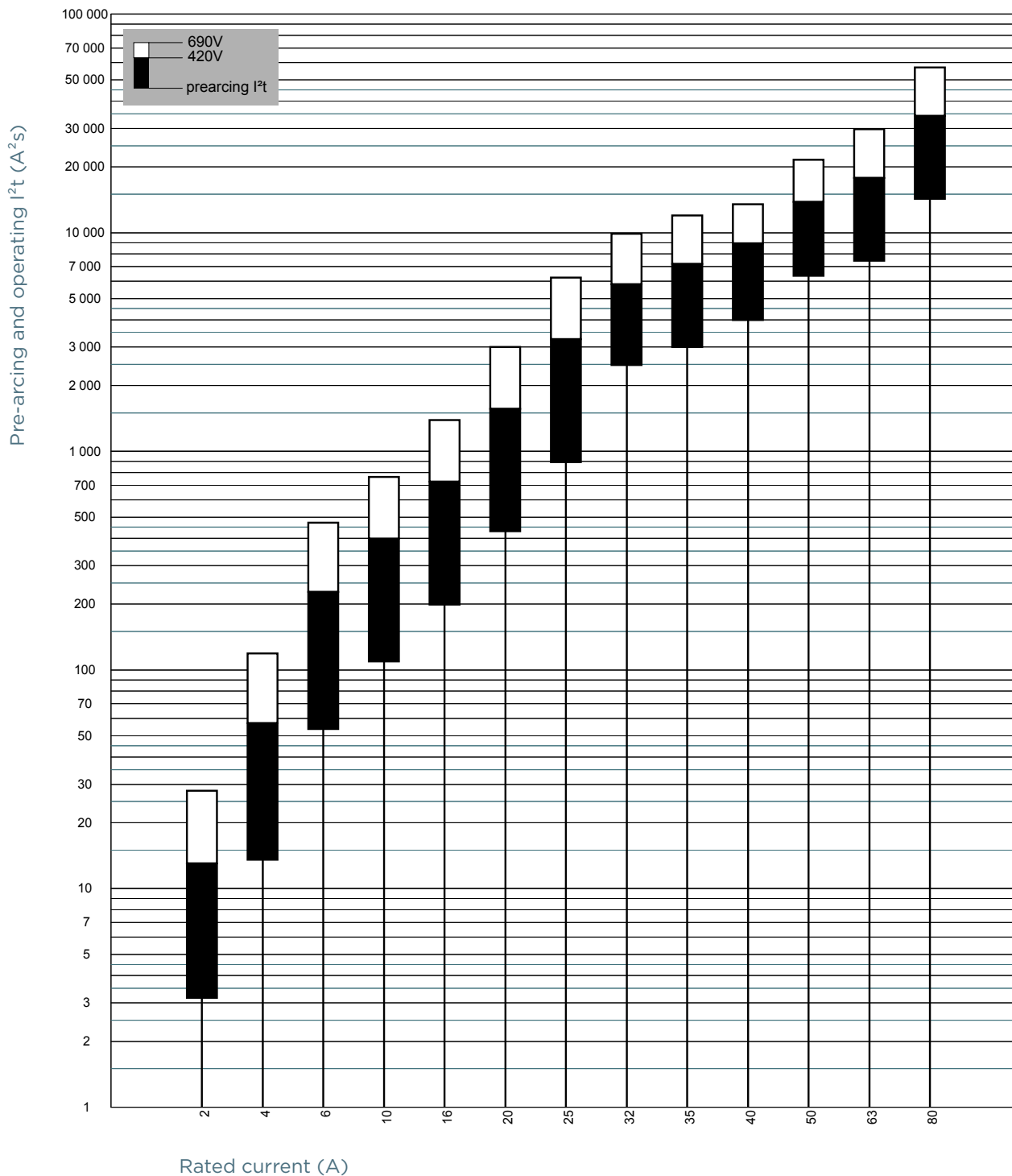

MERSEN reserves the right to change, update or correct, without notice, any information contained in this datasheet.

NH fuse-links gG 690VAC

double indicator/isolated gripping-lugs size 000, 00, 0, 1, 2, 3

PRE-ARCING AND OPERATING I²t CHARACTERISTICS

Size 00

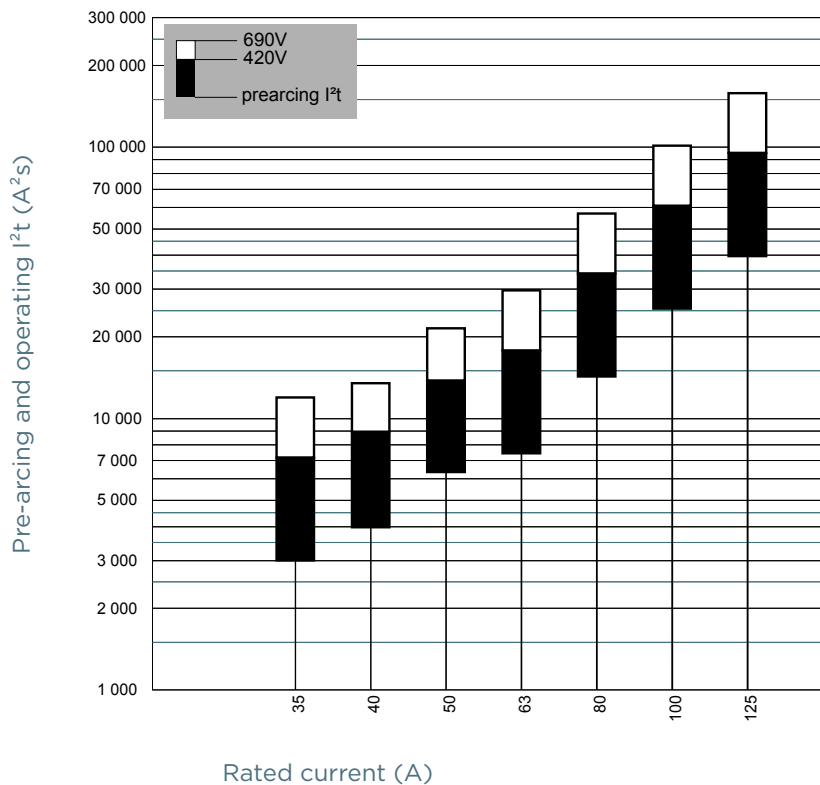

NH fuse-links gG 690VAC

double indicator/isolated gripping-lugs size 000, 00, 0, 1, 2, 3

PRE-ARCING AND OPERATING I²t CHARACTERISTICS

Size 0

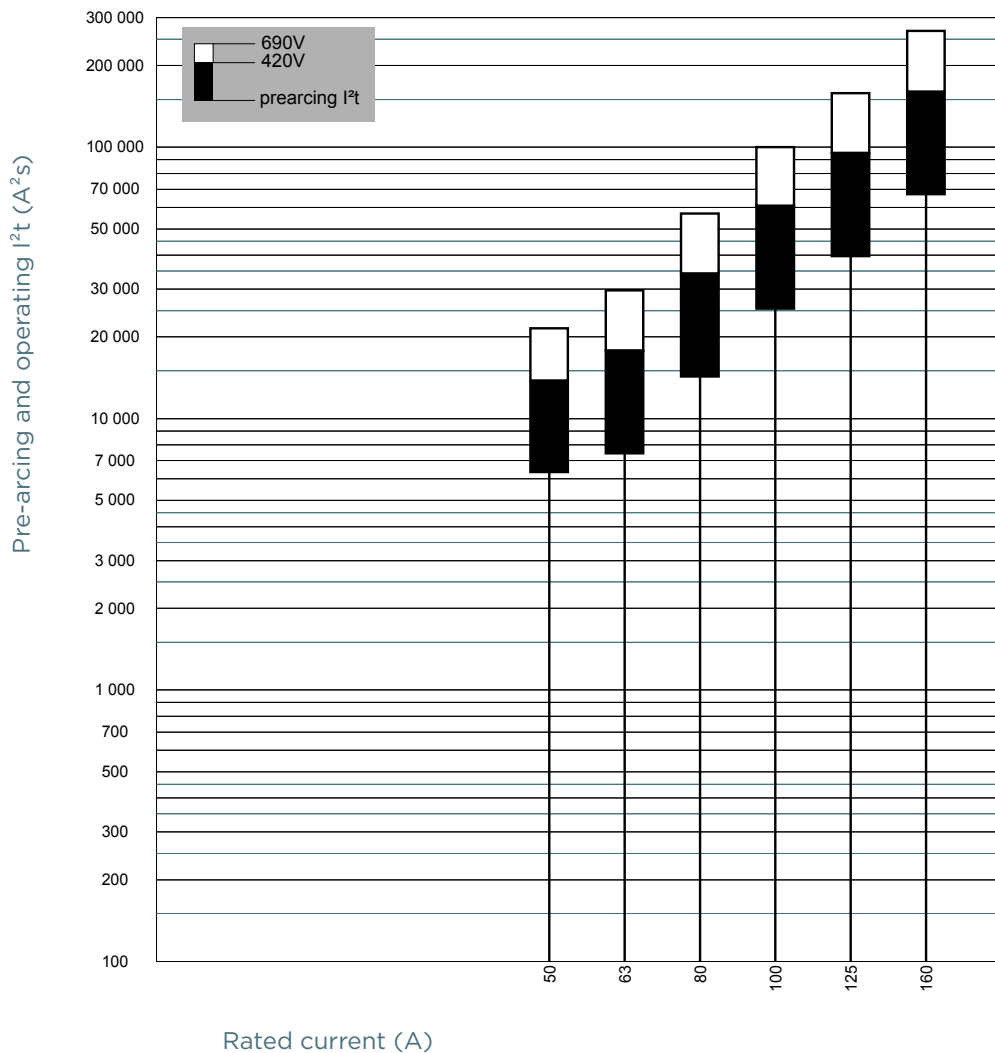

MERSEN reserves the right to change, update or correct, without notice, any information contained in this datasheet.

NH fuse-links gG 690VAC

double indicator/isolated gripping-lugs size 000, 00, 0, 1, 2, 3

PRE-ARCING AND OPERATING I²T CHARACTERISTICS

Size 1

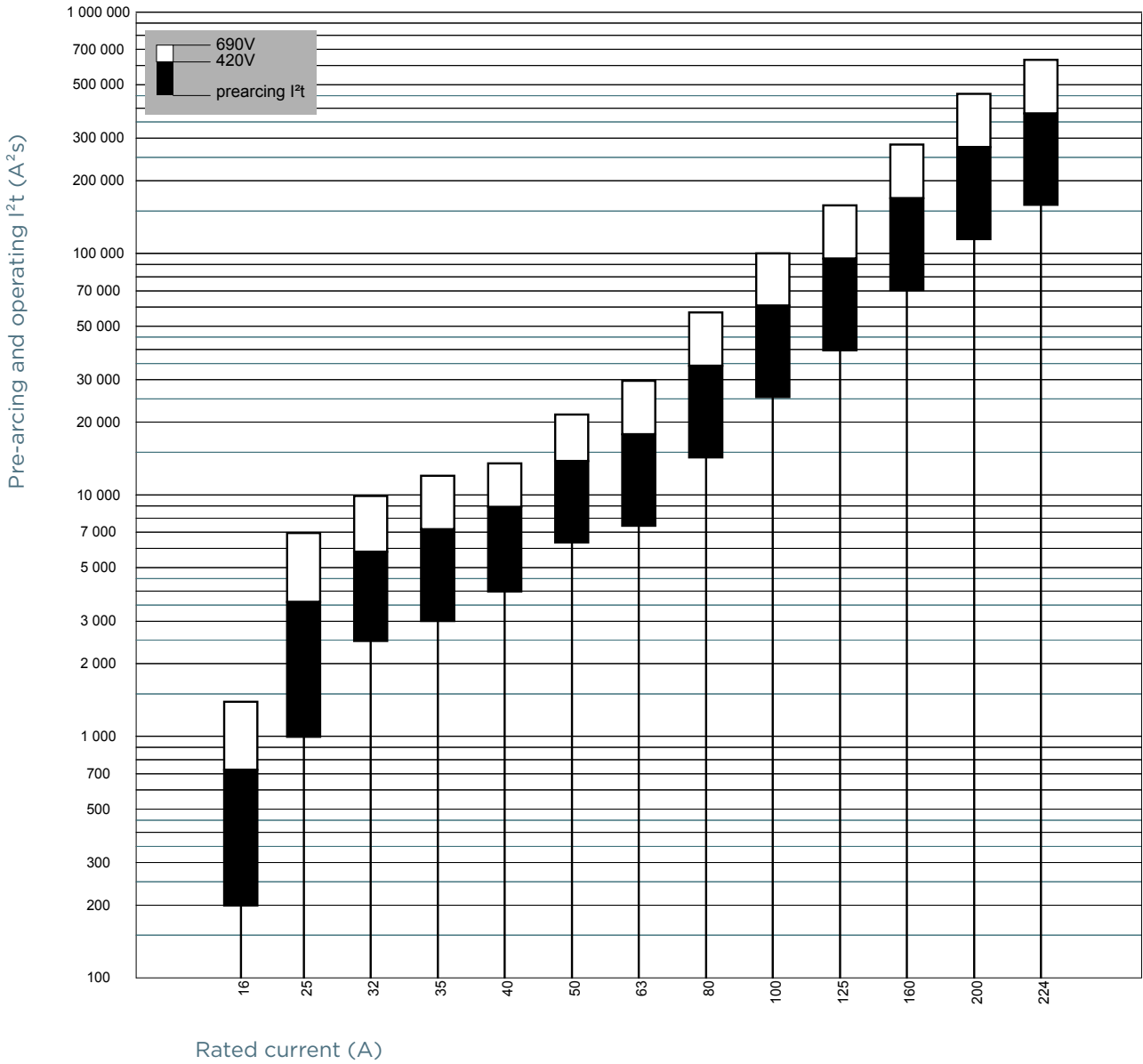

MERSEN reserves the right to change, update or correct, without notice, any information contained in this datasheet.

NH fuse-links gG 690VAC

double indicator/isolated gripping-lugs size 000, 00, 0, 1, 2, 3

PRE-ARCING AND OPERATING I²t CHARACTERISTICS

Size 2

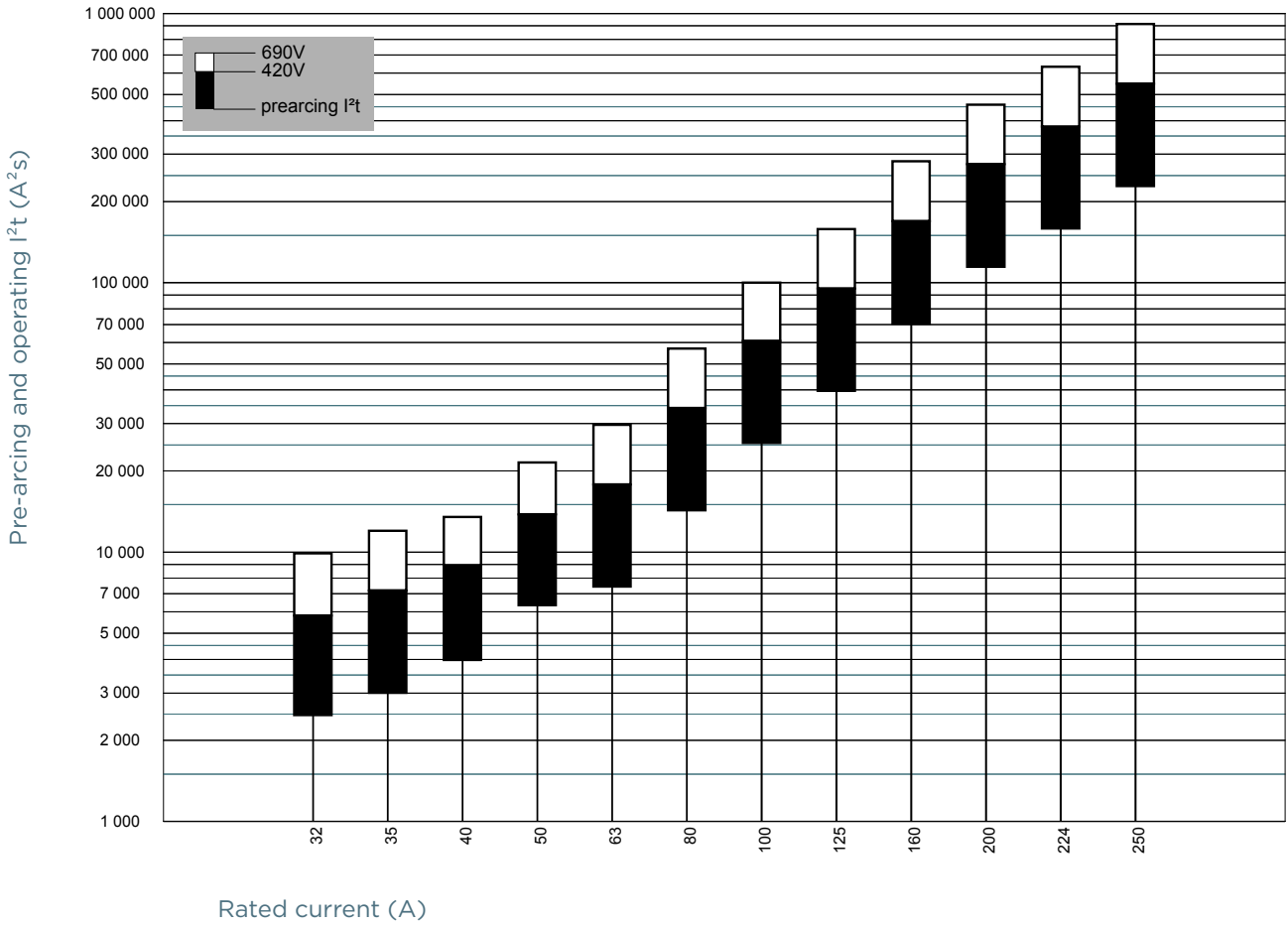

Size 2

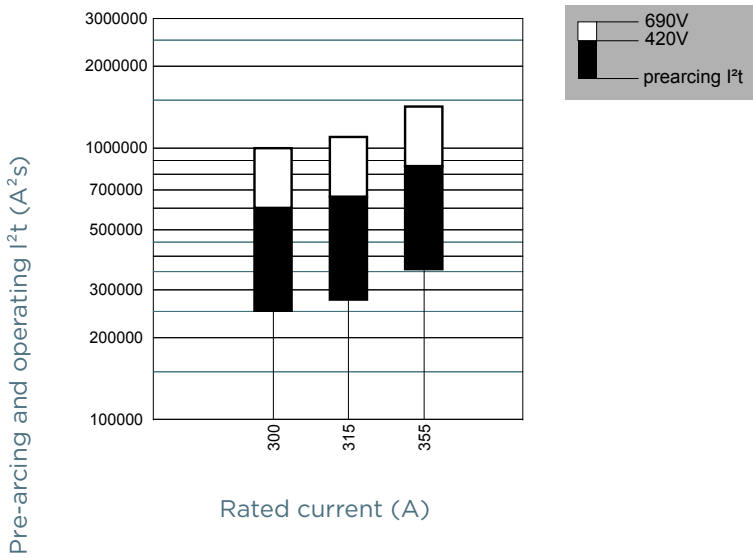

MERSEN reserves the right to change, update or correct, without notice, any information contained in this datasheet.

NH fuse-links gG 690VAC

double indicator/isolated gripping-lugs size 000, 00, 0, 1, 2, 3

PRE-ARCING AND OPERATING I²t CHARACTERISTICS

Size 3

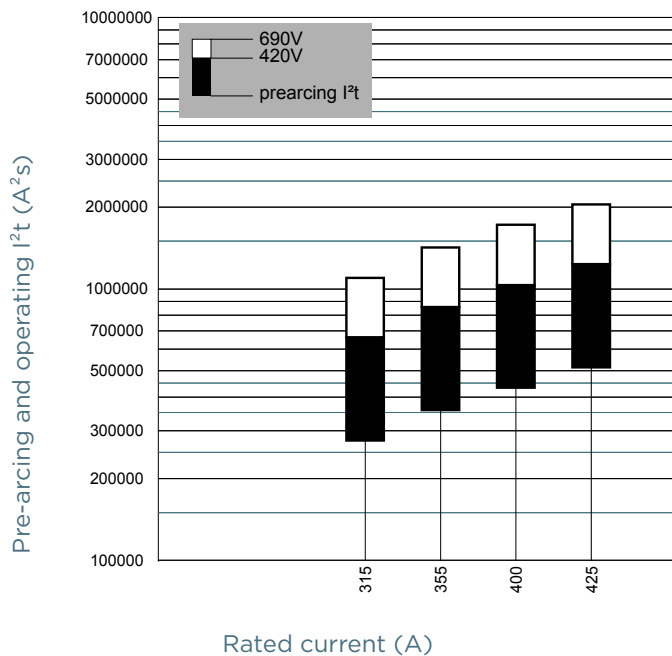

NH fuse-links gG 690VAC

double indicator/isolated gripping-lugs size 000, 00, 0, 1, 2, 3

DIMENSIONS

Size 000 (10004000)

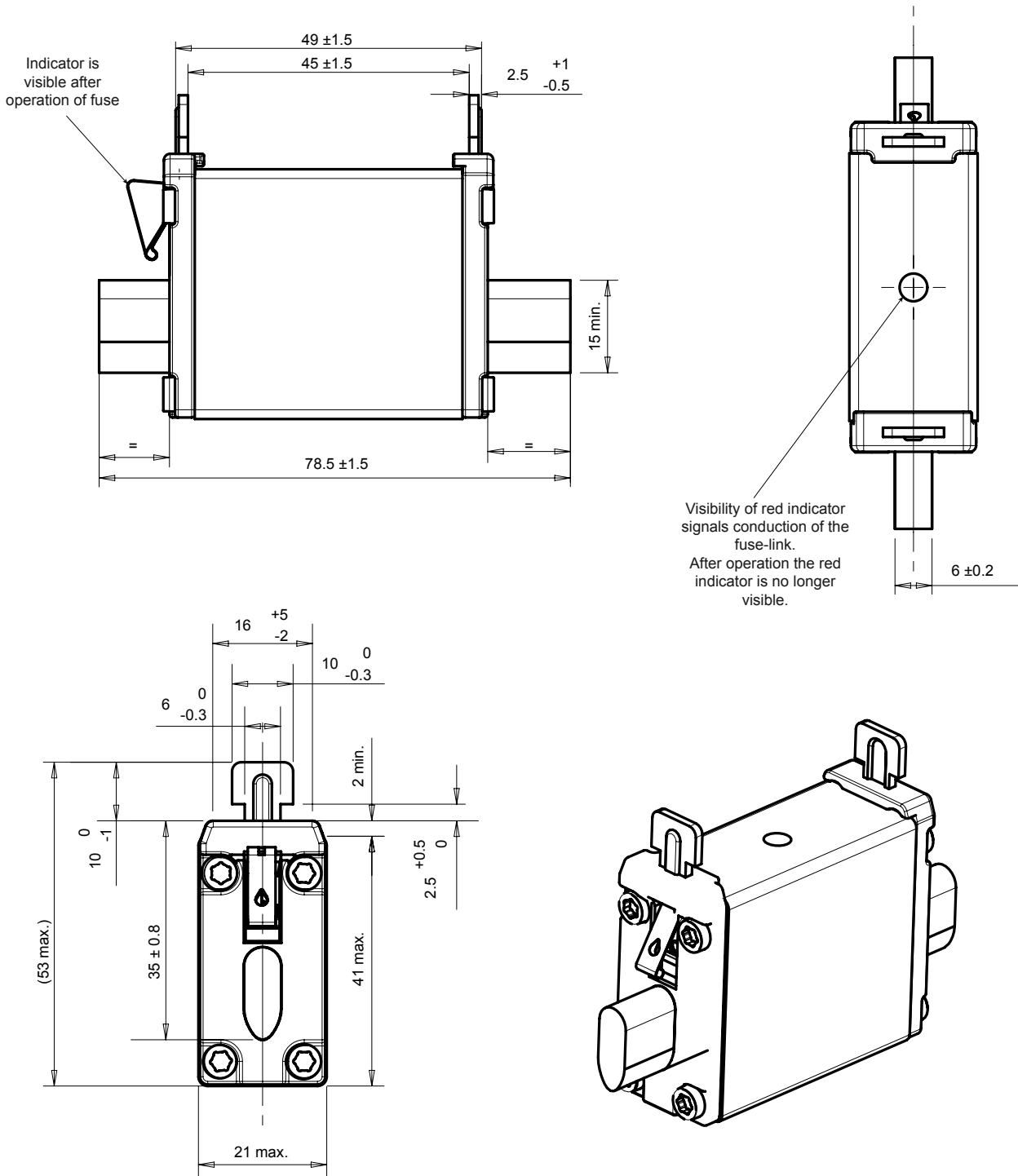

Dimensions in mm

Size 00

