

NH fuse-links aM 500VAC

double indicator/live gripping-lugs size 000, 00, 0, 1, 2, 3

LOW VOLTAGE IEC FUSES

IEC NH FUSE-LINKS



The NH system is classified among plug-in fuse systems and is composed of:

- fuse-base (possibly including terminal covers and phase barriers)
- fuse-link with blade contact
- fuse-link replacement device (LV HRC fuse puller)

Since the design of this system cannot guarantee non-interchangeability of rated current it must be handled by a qualified professional.

Type “aM” NH fuse-links are partial-range breaking capacity fuse-links, used to protect motor circuits as they are strongly current-limiting and have low power losses. They interrupt currents from 6.3 times I_n up to their maximum breaking capacity and are therefore suited for short-circuit protection only. They must be associated with other switchgear for protection against overloads. These fuse-links can have a rated current equal to the motor’s nominal current.

TECHNICAL DATA OVERVIEW

Voltage AC	500 VAC
Ampere Range (A)	2 ... 630 A
Size per Standard	000, 00, 0, 1, 2, 3
Speed/Characteristic	aM
I.R. AC (IEC)	120 kA
Body Material	ceramic
Contact Materials	copper, silver-plated

FEATURES & BENEFITS

- Dimensions according to DIN 43 620 parts 1 to 4
- Non-isolated gripping lugs
- Double indicator
- Lead free contact blades
- 0% cadmium

APPLICATIONS

- aM: Partial purpose, motor circuit protection

STANDARDS

- VDE 0636 Part 201
- IEC 60269-1 and -2



NH fuse-links aM 500VAC

double indicator/live gripping-lugs size 000, 00, 0, 1, 2, 3

PRODUCT RANGE



NH000AM50V63

Size 000 aM 500VAC

Catalog number	Item number	Rated voltage AC (IEC)	Rated current I _n	Power dissipation at I _n	Weight	Package
NH000AM50V2	K232493	500 V	2 A	0.1 W	0.13 kg	2
NH000AM50V4	L232494	500 V	4 A	0.2 W	0.13 kg	2
NH000AM50V6	M232495	500 V	6 A	0.3 W	0.13 kg	2
NH000AM50V10	N232496	500 V	10 A	0.5 W	0.13 kg	2
NH000AM50V16	P232497	500 V	16 A	0.7 W	0.13 kg	2
NH000AM50V20	Q232498	500 V	20 A	0.9 W	0.13 kg	2
NH000AM50V25	R232499	500 V	25 A	1.2 W	0.13 kg	2
NH000AM50V32	S232500	500 V	32 A	1.5 W	0.13 kg	2
NH000AM50V35	T232501	500 V	35 A	1.6 W	0.13 kg	2
NH000AM50V40	V232502	500 V	40 A	1.8 W	0.13 kg	2
NH000AM50V50	W232503	500 V	50 A	2.3 W	0.13 kg	2
NH000AM50V63	X232504	500 V	63 A	2.9 W	0.13 kg	2
NH000AM50V80	C227863	500 V	80 A	3.6 W	0.13 kg	2



NH00AM50V100

Size 00 aM 500VAC

Catalog number	Item number	Rated voltage AC (IEC)	Rated current I _n	Power dissipation at I _n	Weight	Package
NH00AM50V100	Y232505	500 V	100 A	5.8 W	0.2 kg	2
NH00AM50V125	Z232506	500 V	125 A	6.4 W	0.2 kg	2
NH00AM50V160	J227869	500 V	160 A	7.9 W	0.2 kg	2



NH0AM50V100

Size 0 aM 500VAC

Catalog number	Item number	Rated voltage AC (IEC)	Rated current I _n	Power dissipation at I _n	Weight	Package
NH0AM50V100	A232507	500 V	100 A	6 W	0.26 kg	2
NH0AM50V125	B232508	500 V	125 A	7.9 W	0.26 kg	2
NH0AM50V160	C232509	500 V	160 A	10.5 W	0.26 kg	2
NH0AM50V200	A227884	500 V	200 A	11.8 W	0.26 kg	2



NH1AM50V200

Size 1 aM 500VAC

Catalog number	Item number	Rated voltage AC (IEC)	Rated current I _n	Power dissipation at I _n	Weight	Package
NH1AM50V100	D232510	500 V	100 A	5.8 W	0.42 kg	2
NH1AM50V125	E232511	500 V	125 A	7.5 W	0.42 kg	2
NH1AM50V160	F232512	500 V	160 A	10.4 W	0.42 kg	2
NH1AM50V200	G232513	500 V	200 A	14.2 W	0.42 kg	2
NH1AM50V224	H232514	500 V	224 A	15.8 W	0.42 kg	2
NH1AM50V315	K227962	500 V	315 A	22.1 W	0.42 kg	2



NH2AM50V250

Size 2 aM 500VAC

Catalog number	Item number	Rated voltage AC (IEC)	Rated current I _n	Power dissipation at I _n	Weight	Package
NH2AM50V250	K232516	500 V	250 A	16.8 W	0.64 kg	2
NH2AM50V315	L232517	500 V	315 A	23.1 W	0.64 kg	2
NH2AM50V355	M232518	500 V	355 A	26.4 W	0.64 kg	2
NH2AM50V400	N232519	500 V	400 A	29.7 W	0.64 kg	2

MERSEN reserves the right to change, update or correct, without notice, any information contained in this datasheet.

NH fuse-links aM 500VAC

double indicator/live gripping-lugs size 000, 00, 0, 1, 2, 3

PRODUCT RANGE



NH3AM50V630

Size 3 aM 500VAC

Catalog number	Item number	Rated voltage AC (IEC)	Rated current I _n	Power dissipation at I _n	Weight	Package
NH3AM50V315	P232520	500 V	315 A	21 W	1.05 kg	1
NH3AM50V355	Q232521	500 V	355 A	23.3 W	1.05 kg	1
NH3AM50V400	R232522	500 V	400 A	29.1 W	1.05 kg	1
NH3AM50V425	S232523	500 V	425 A	29.1 W	1.05 kg	1
NH3AM50V450	T232524	500 V	450 A	34 W	1.05 kg	1
NH3AM50V500	V232525	500 V	500 A	42 W	1.05 kg	1
NH3AM50V630	M227987	500 V	630 A	42 W	1.05 kg	1

TECHNICAL DATA

	Size 000	Size 00	Size 0	Size 1	Size 2	Size 3
Rated current	2 ... 80 A	100 ... 160 A	100 ... 200 A	100 ... 315 A	250 ... 400 A	315 ... 630 A
Rated breaking capacity AC	120 kA	120 kA	120 kA	120 kA	120 kA	120 kA
Rated voltage AC	500 V	500 V	500 V	500 V	500 V	500 V
Indication System	double indicator	double indicator	double indicator	double indicator	double indicator	double indicator
Width	21 mm	30 mm	30 mm	40 mm	52 mm	72 mm

NH fuse-links aM 500VAC

double indicator/live gripping-lugs size 000, 00, 0, 1, 2, 3

TIME CURRENT CHARACTERISTIC CURVES

Size 000

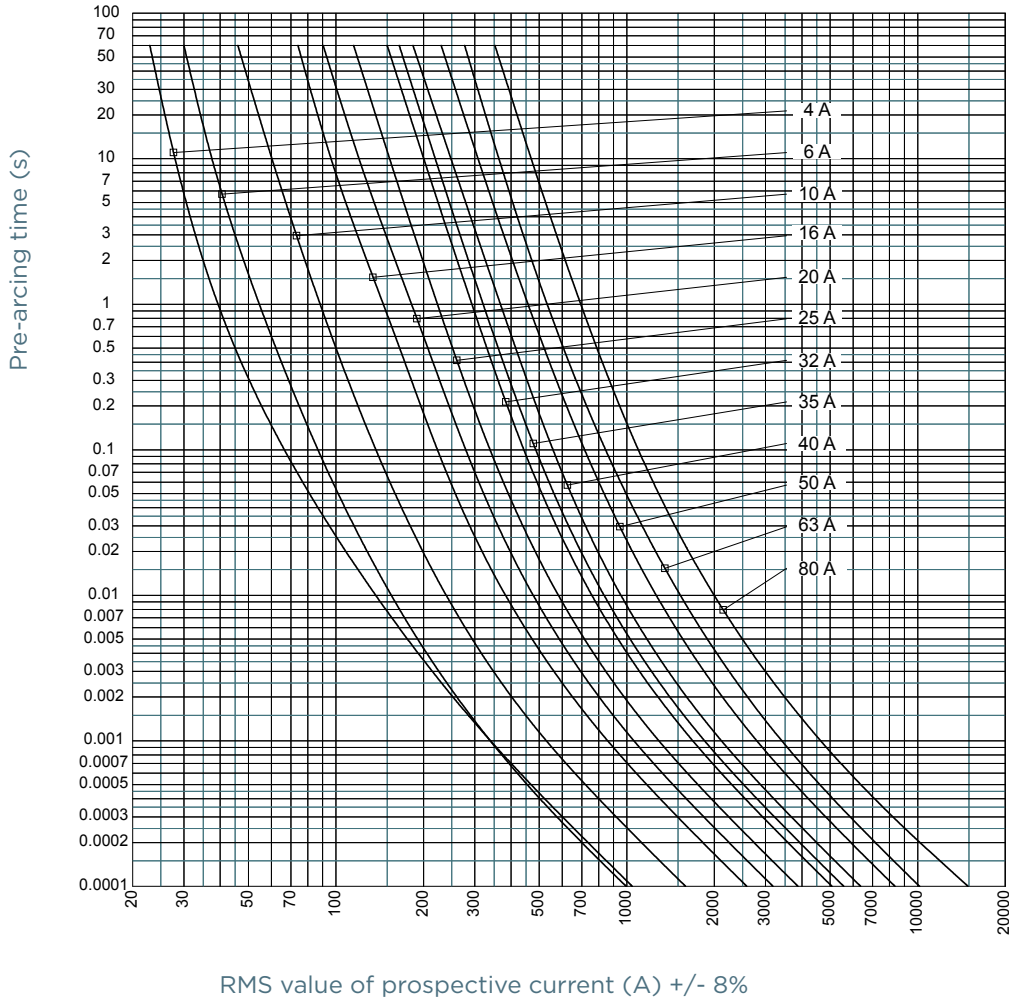

MERSEN reserves the right to change, update or correct, without notice, any information contained in this datasheet.

NH fuse-links aM 500VAC

double indicator/live gripping-lugs size 000, 00, 0, 1, 2, 3

TIME CURRENT CHARACTERISTIC CURVES

Size 00

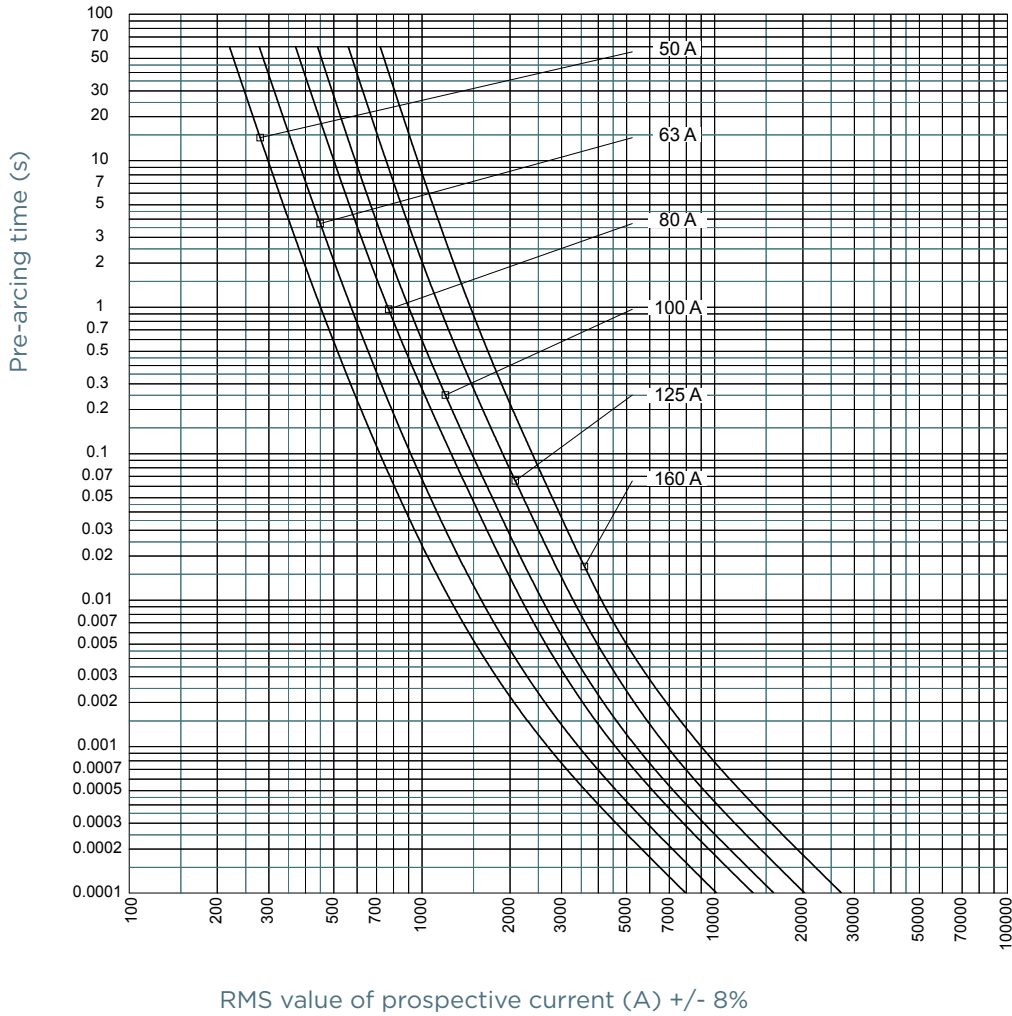

MERSEN reserves the right to change, update or correct, without notice, any information contained in this datasheet.

NH fuse-links aM 500VAC

double indicator/live gripping-lugs size 000, 00, 0, 1, 2, 3

TIME CURRENT CHARACTERISTIC CURVES

Size 0

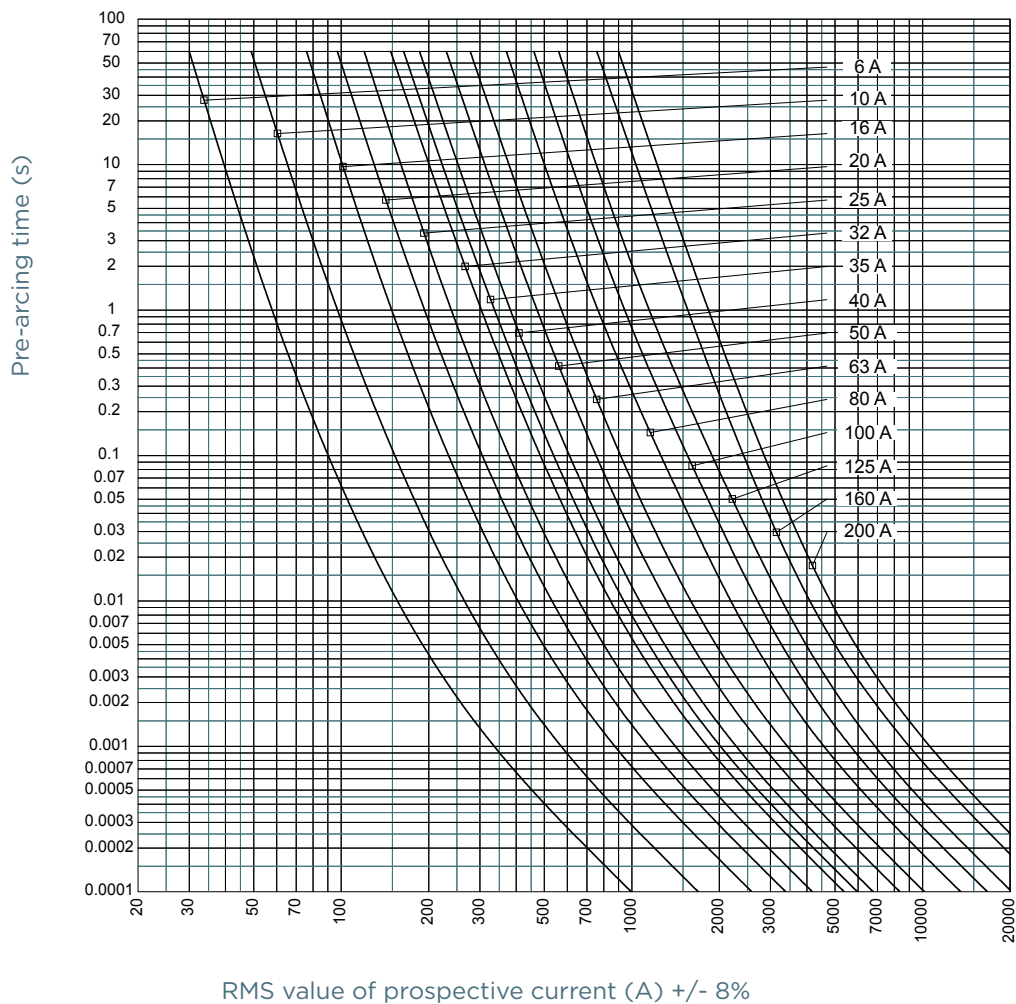

MERSEN reserves the right to change, update or correct, without notice, any information contained in this datasheet.

NH fuse-links aM 500VAC

double indicator/live gripping-lugs size 000, 00, 0, 1, 2, 3

TIME CURRENT CHARACTERISTIC CURVES

Size 1

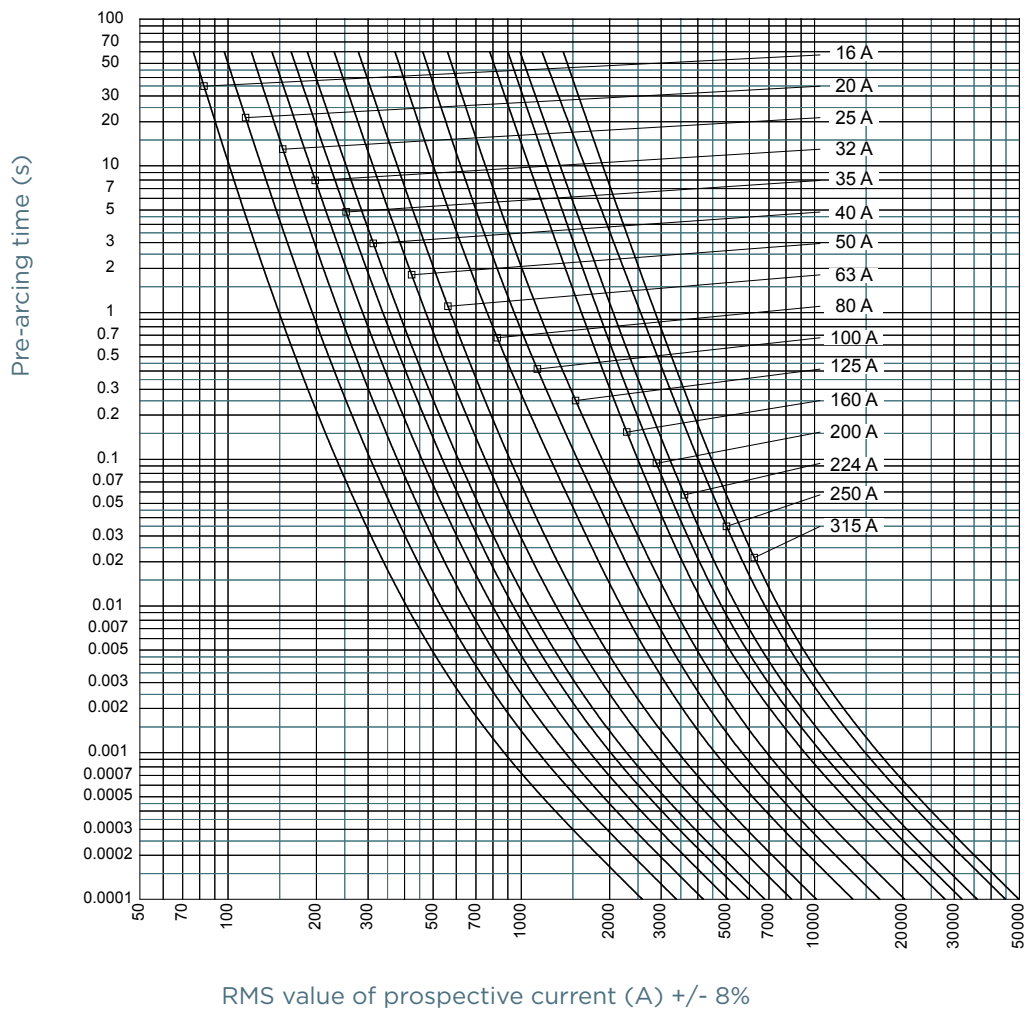

MERSEN reserves the right to change, update or correct, without notice, any information contained in this datasheet.

NH fuse-links aM 500VAC

double indicator/live gripping-lugs size 000, 00, 0, 1, 2, 3

TIME CURRENT CHARACTERISTIC CURVES

Size 2

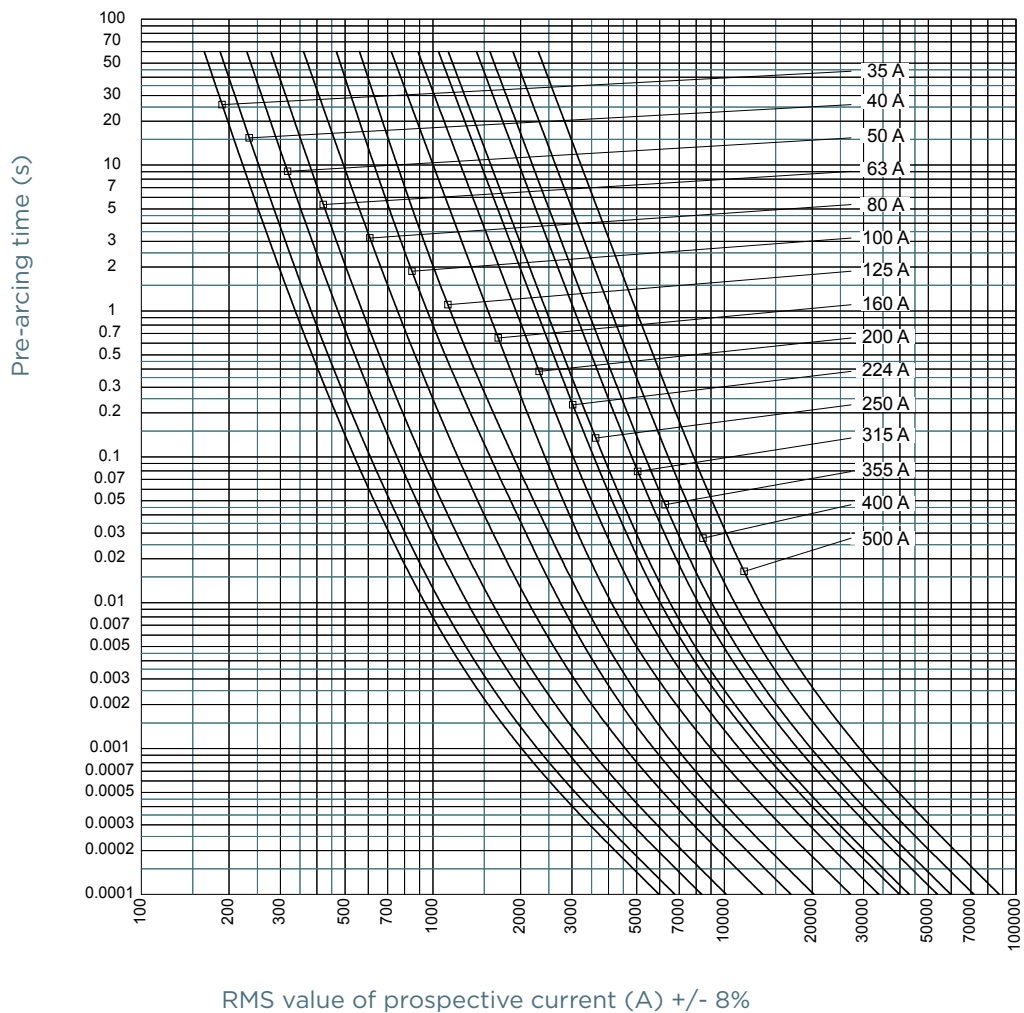

MERSEN reserves the right to change, update or correct, without notice, any information contained in this datasheet.

NH fuse-links aM 500VAC

double indicator/live gripping-lugs size 000, 00, 0, 1, 2, 3

TIME CURRENT CHARACTERISTIC CURVES

Size 3

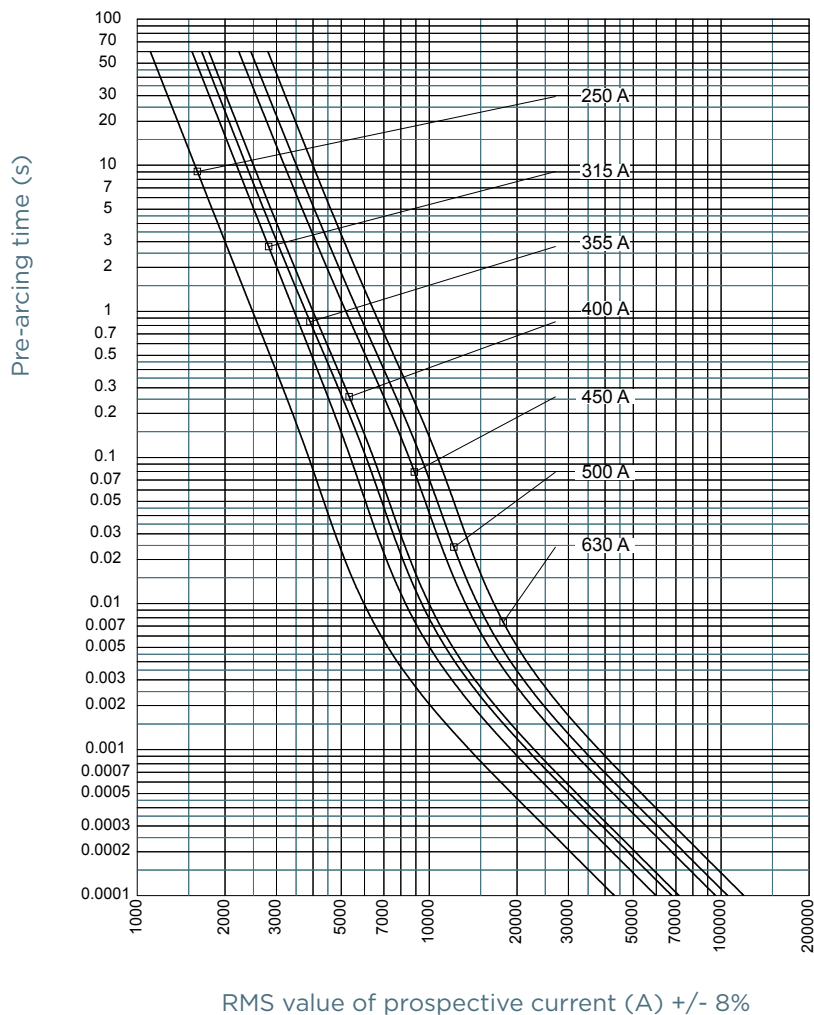

CUT-OFF CURRENT CHARACTERISTIC

Size 000

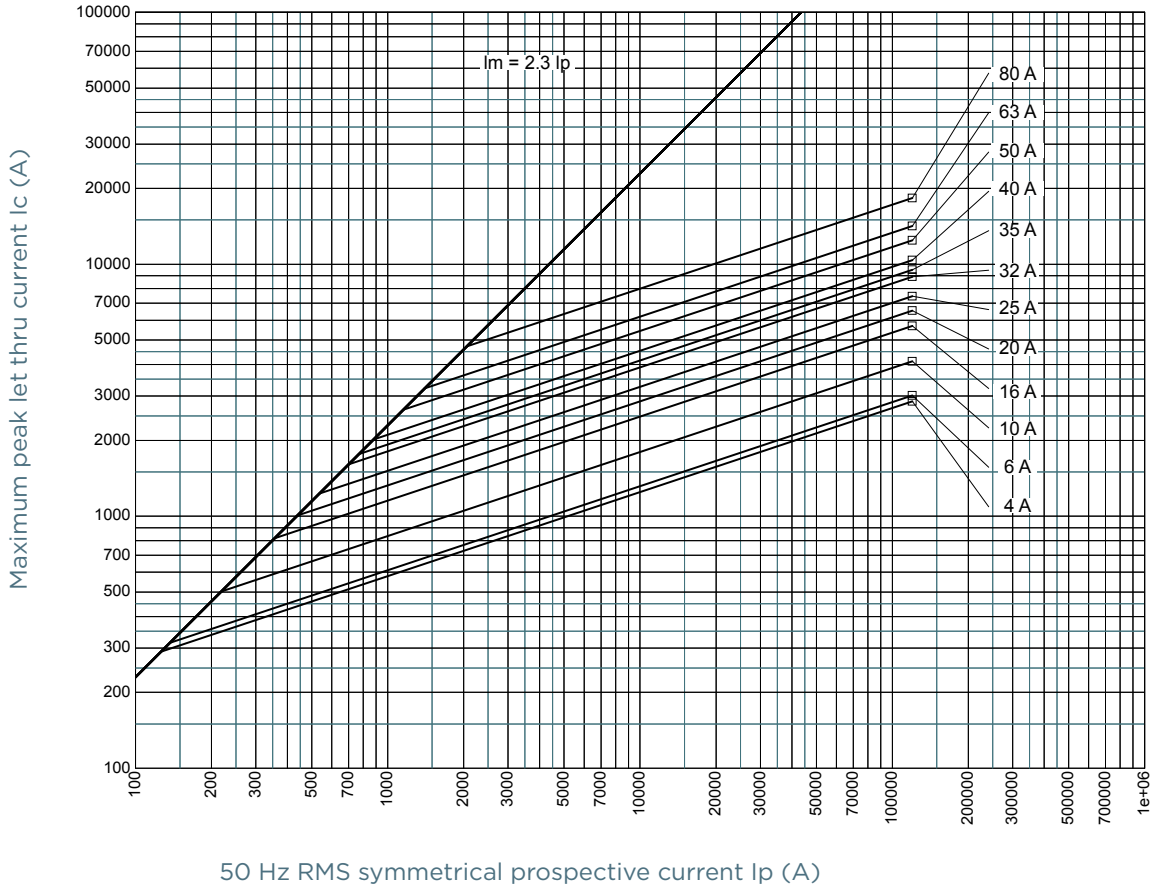

Size 00

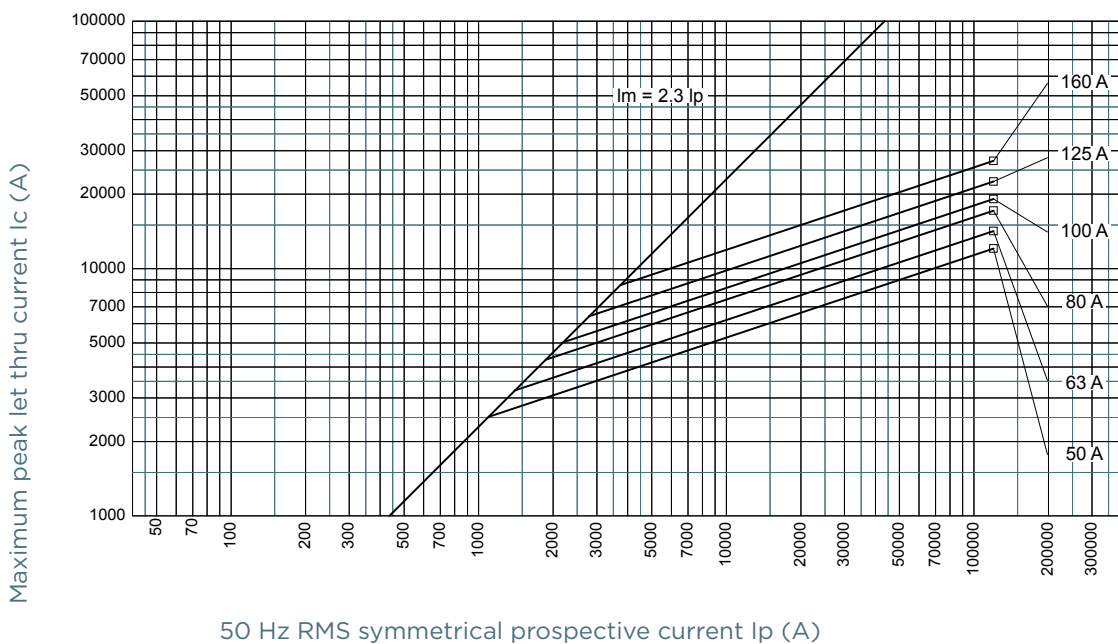

NH fuse-links aM 500VAC

double indicator/live gripping-lugs size 000, 00, 0, 1, 2, 3

CUT-OFF CURRENT CHARACTERISTIC

Size 0

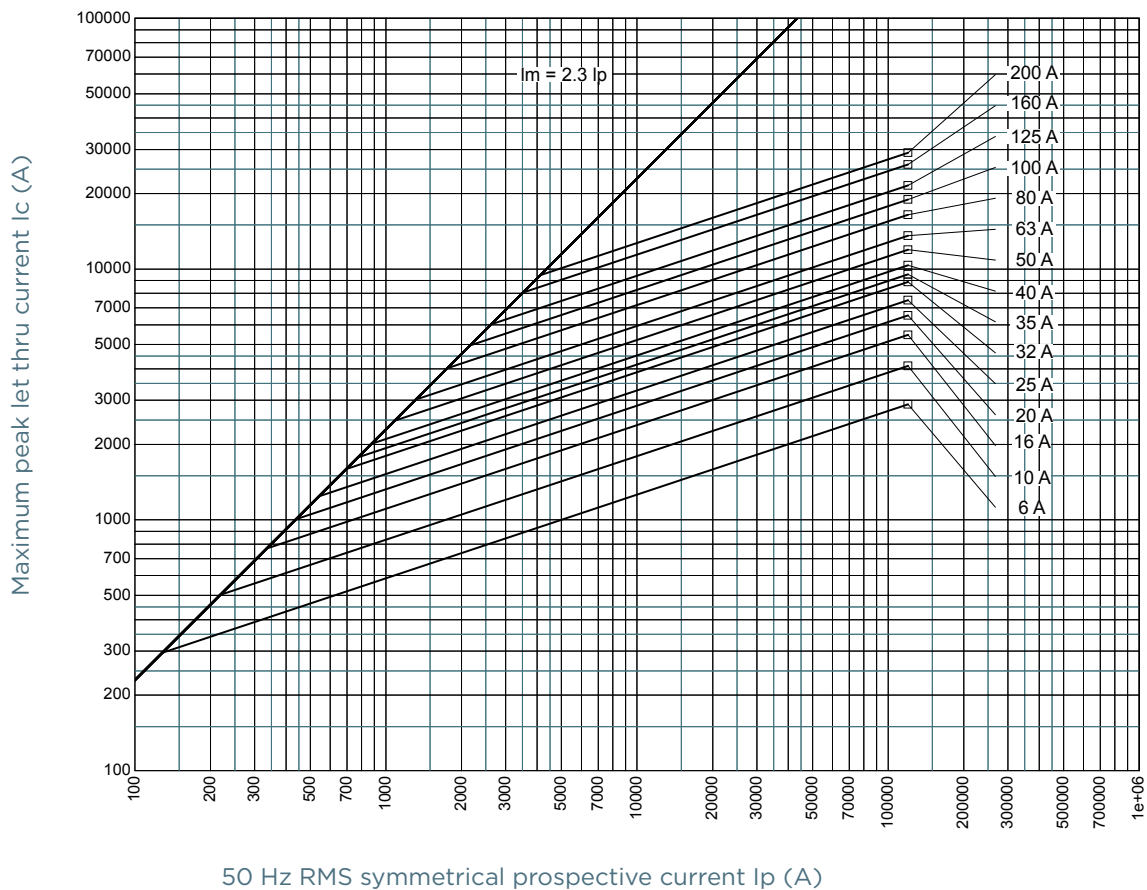

MERSEN reserves the right to change, update or correct, without notice, any information contained in this datasheet.

NH fuse-links aM 500VAC

double indicator/live gripping-lugs size 000, 00, 0, 1, 2, 3

CUT-OFF CURRENT CHARACTERISTIC

Size 1

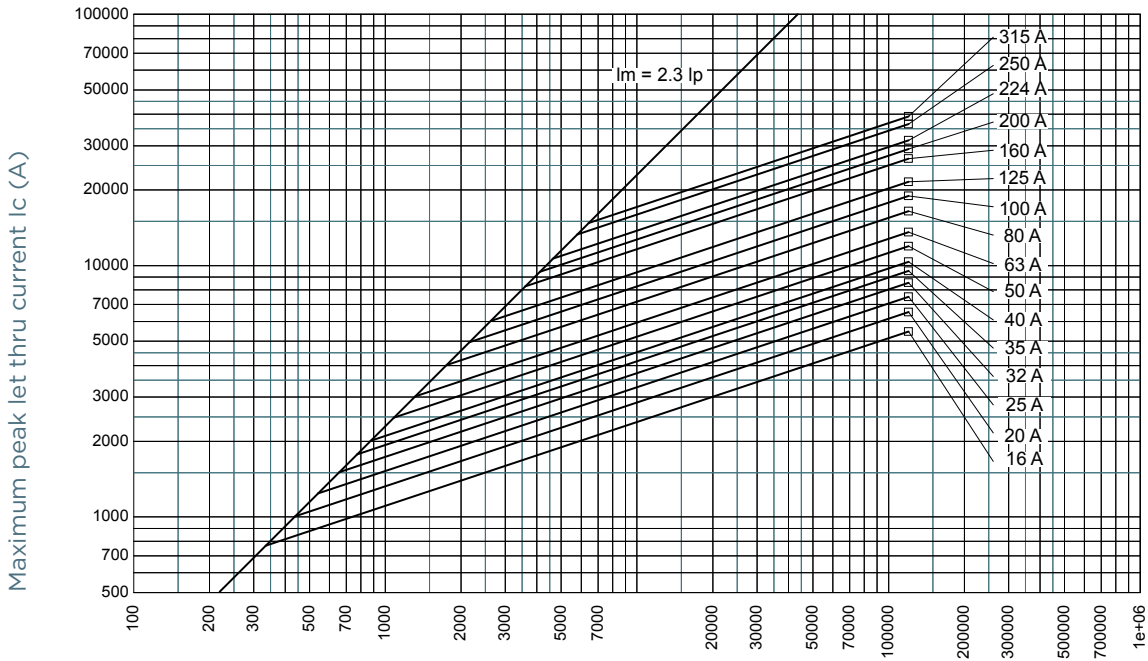

Size 2

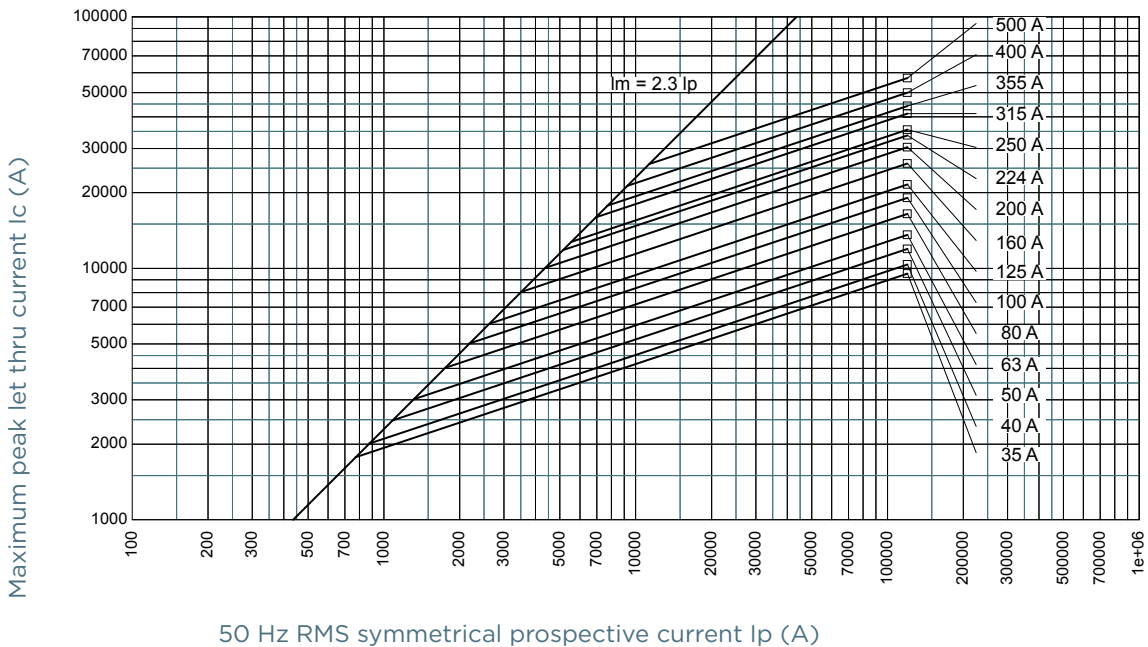

MERSEN reserves the right to change, update or correct, without notice, any information contained in this datasheet.

CUT-OFF CURRENT CHARACTERISTIC

Size 3

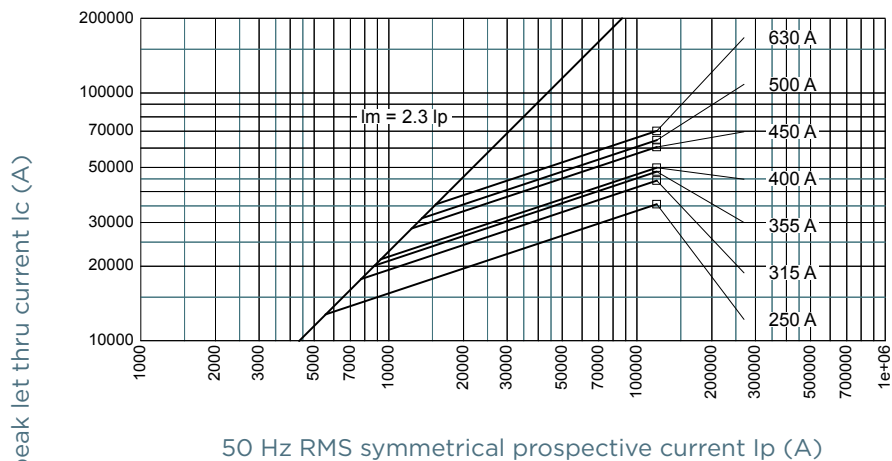

NH fuse-links aM 500VAC

double indicator/live gripping-lugs size 000, 00, 0, 1, 2, 3

PRE-ARCING AND OPERATING I²t CHARACTERISTICS

Size 000

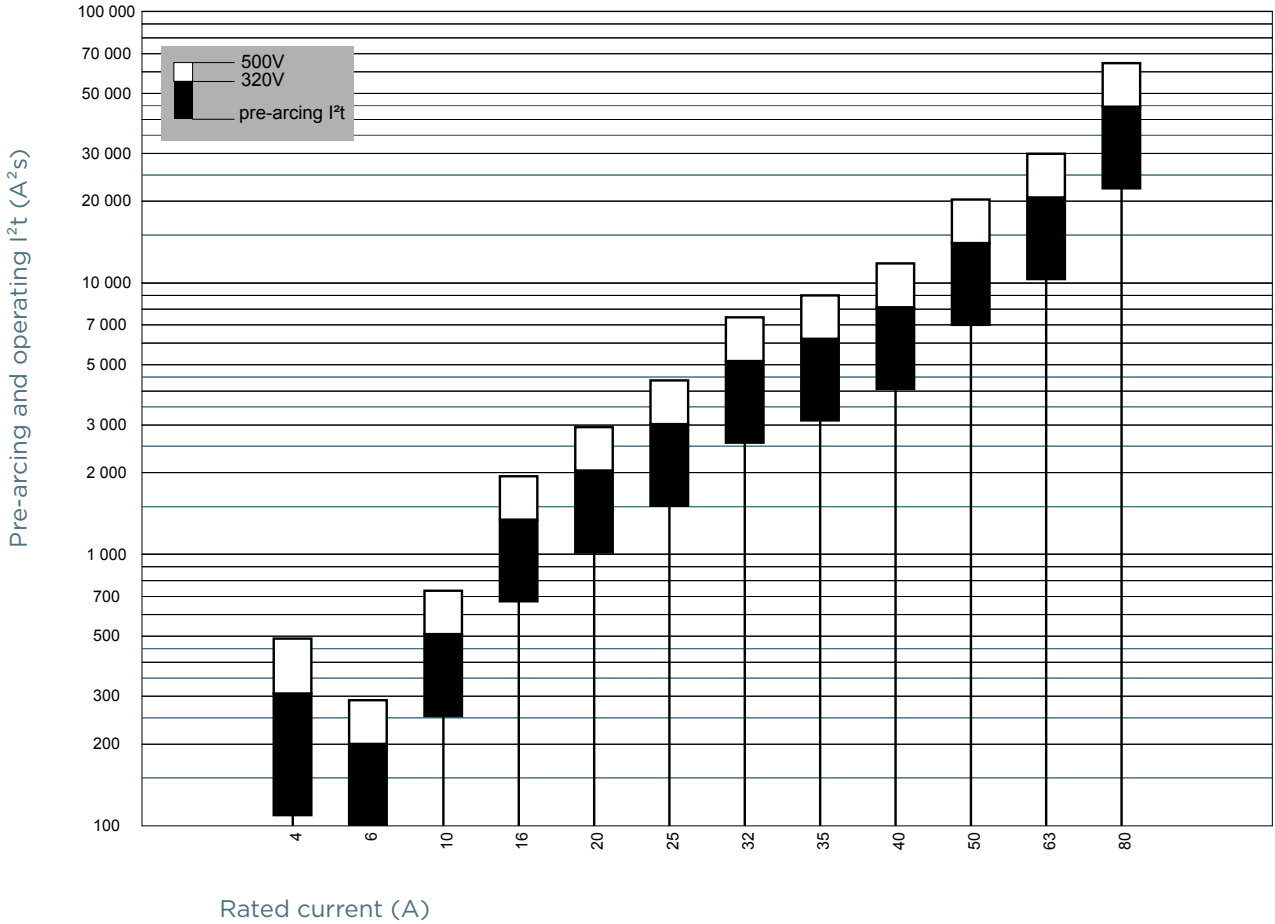

Size 00

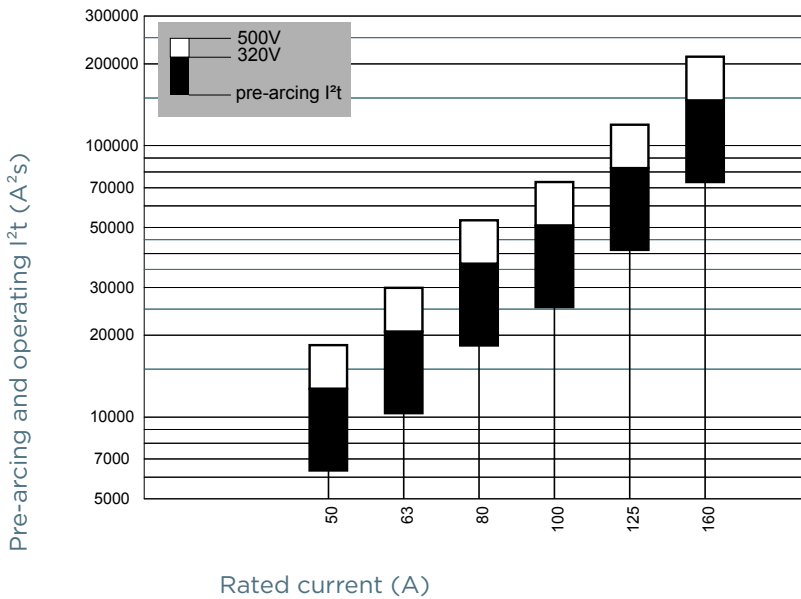

MERSEN reserves the right to change, update or correct, without notice, any information contained in this datasheet.

NH fuse-links aM 500VAC

double indicator/live gripping-lugs size 000, 00, 0, 1, 2, 3

PRE-ARCING AND OPERATING I²t CHARACTERISTICS

Size 0

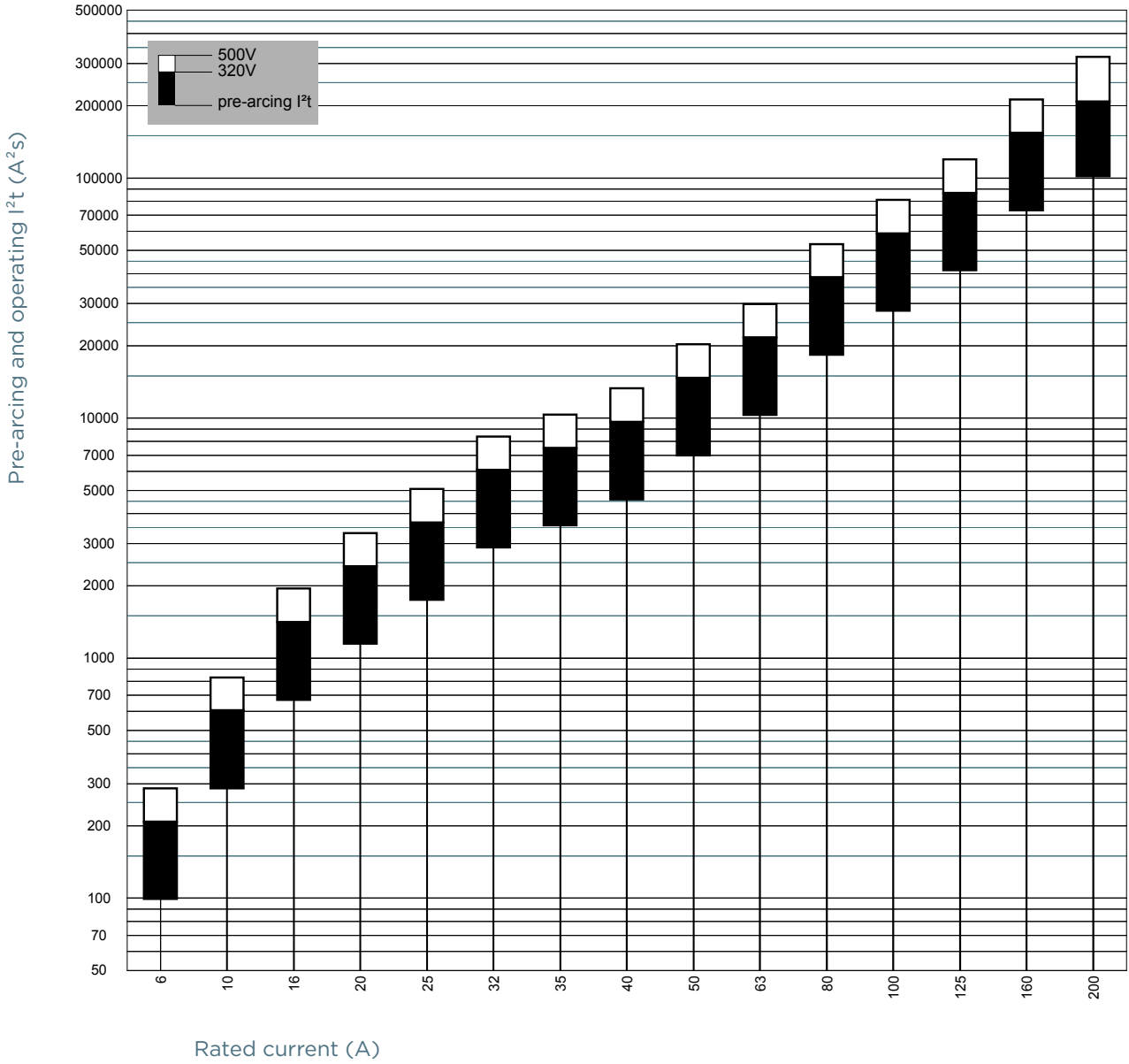

MERSEN reserves the right to change, update or correct, without notice, any information contained in this datasheet.

NH fuse-links aM 500VAC

double indicator/live gripping-lugs size 000, 00, 0, 1, 2, 3

PRE-ARCING AND OPERATING I^2t CHARACTERISTICS

Size 1

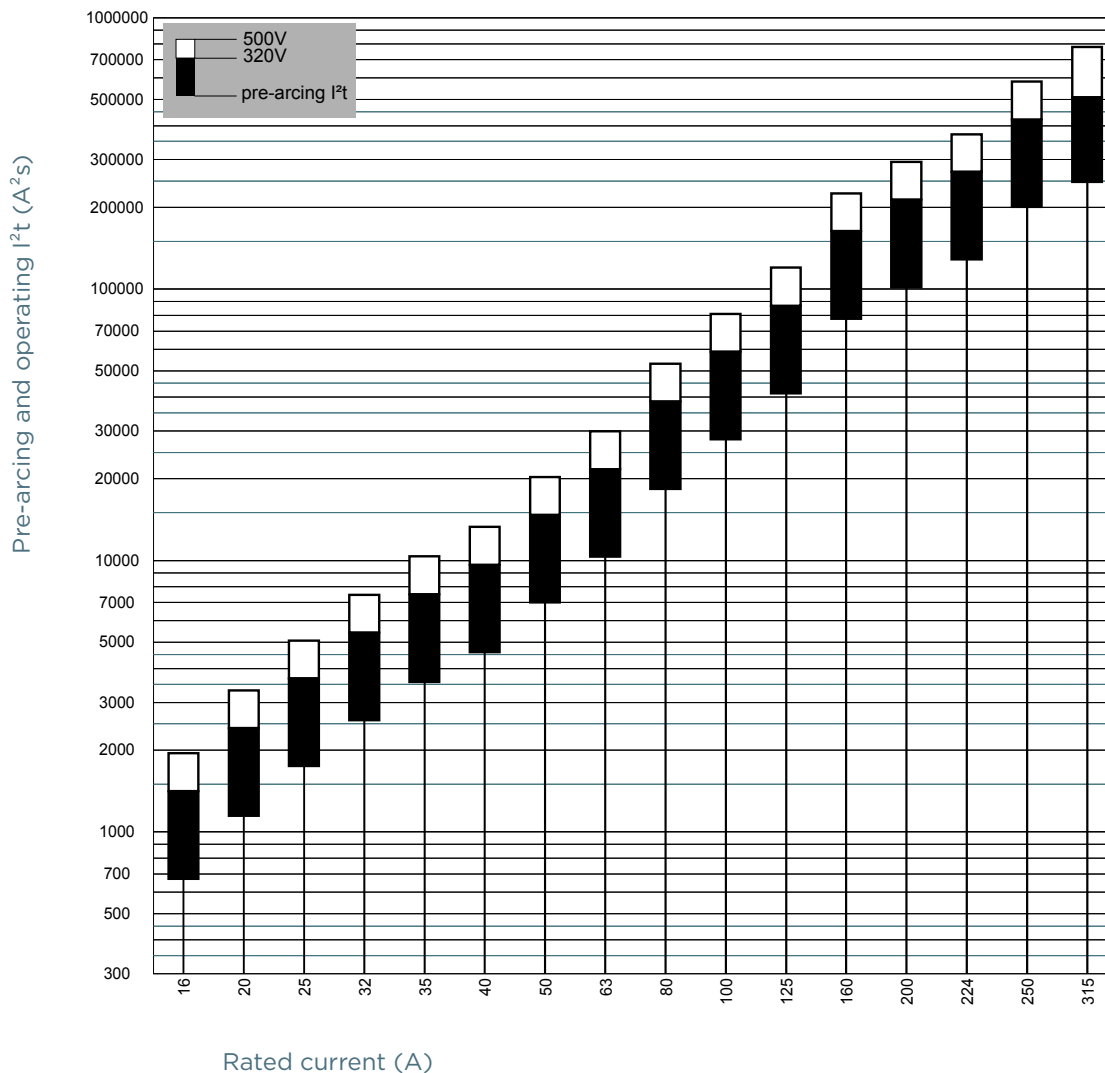

MERSEN reserves the right to change, update or correct, without notice, any information contained in this datasheet.

NH fuse-links aM 500VAC

double indicator/live gripping-lugs size 000, 00, 0, 1, 2, 3

PRE-ARCING AND OPERATING I²t CHARACTERISTICS

Size 2

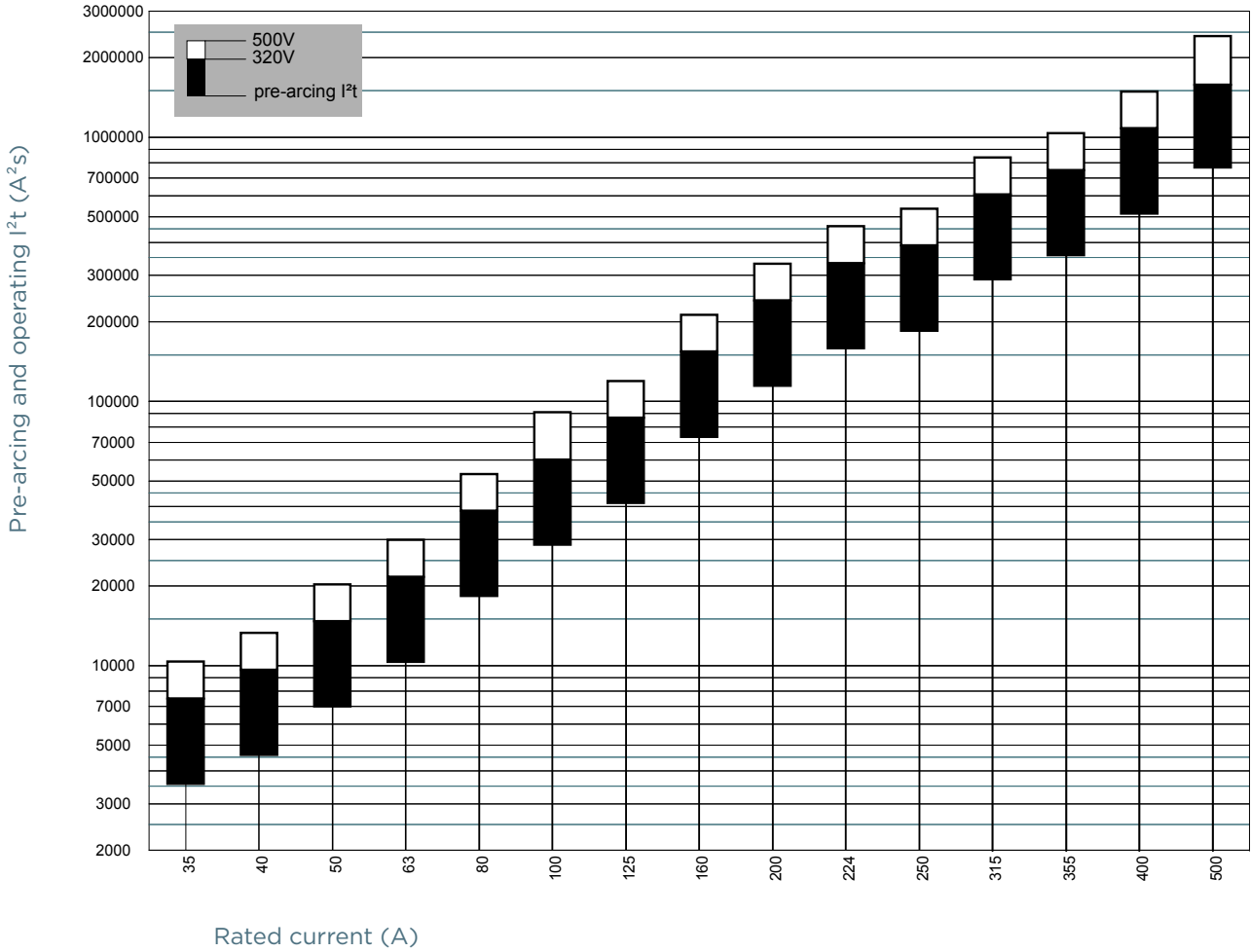

Size 3

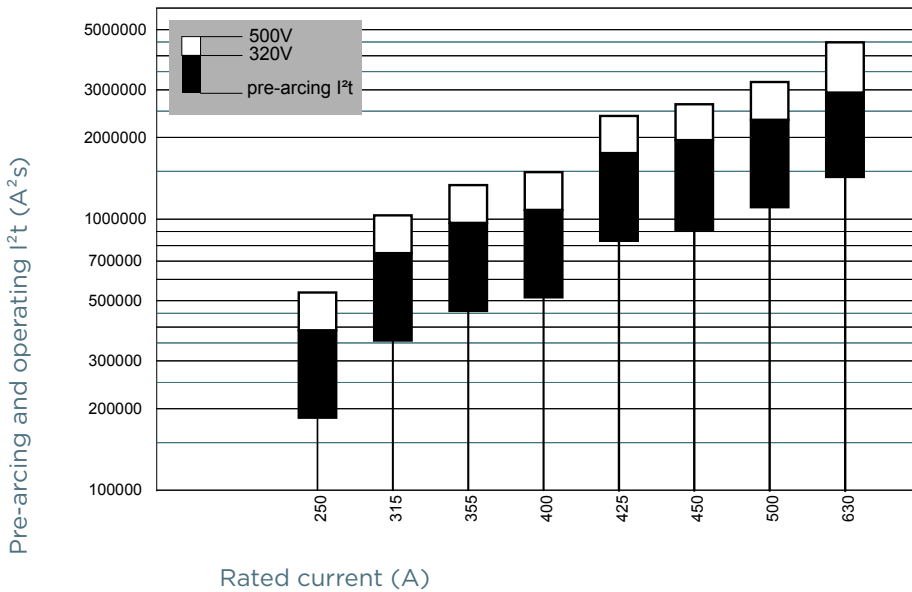

MERSEN reserves the right to change, update or correct, without notice, any information contained in this datasheet.

NH fuse-links aM 500VAC

double indicator/live gripping-lugs size 000, 00, 0, 1, 2, 3

DIMENSIONS

size 000 with double indicator

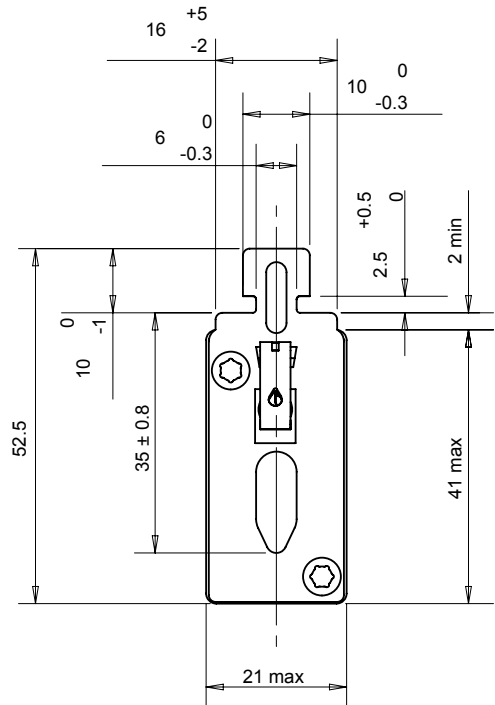
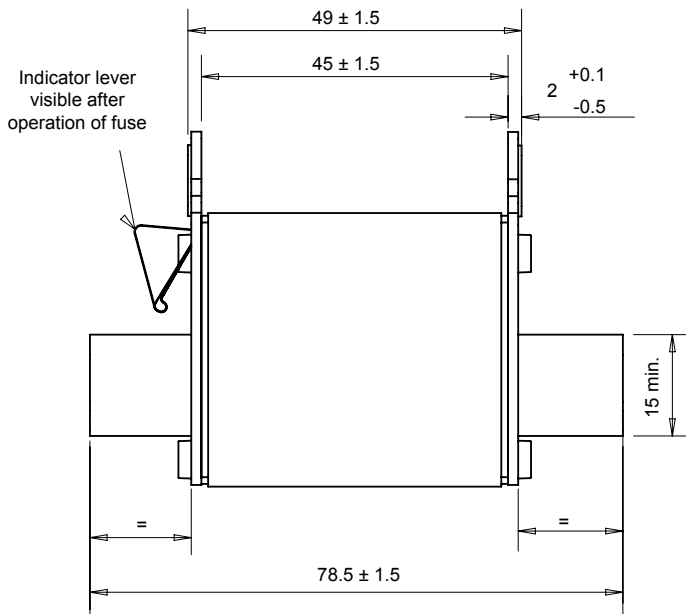

Visibility of red indicator signals conduction of the fuse-link.
After operation the red indicator is no longer visible

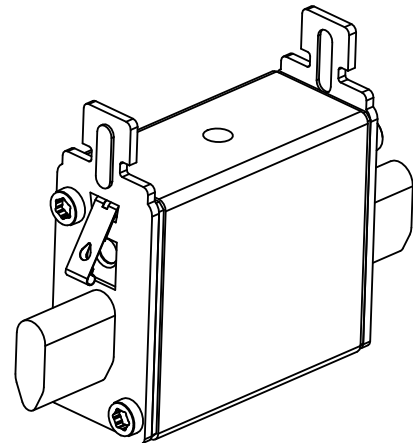
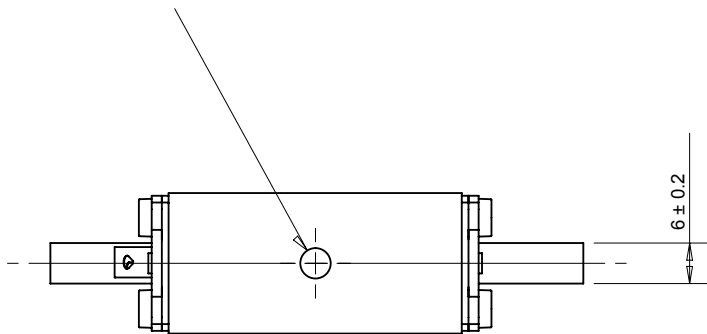

Dimensions in mm

NH fuse-links aM 500VAC

double indicator/live gripping-lugs size 000, 00, 0, 1, 2, 3

DIMENSIONS

size 00 with double indicator

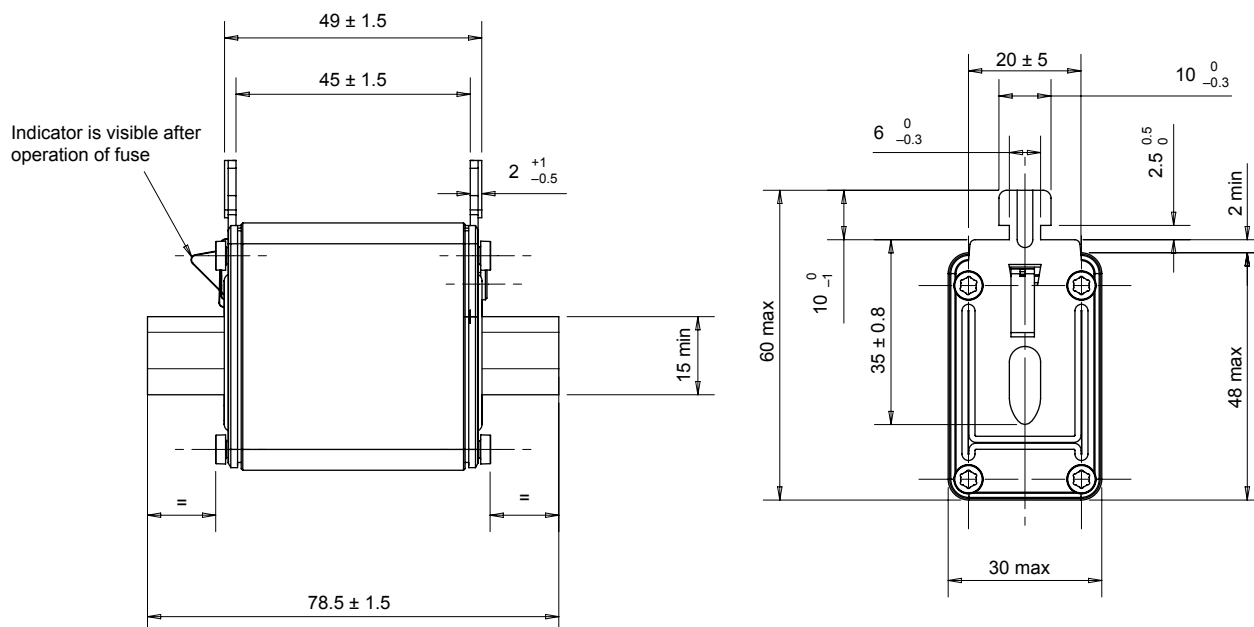

- Visibility of red indicator signals conduction of the fuse-link. After operation the red indicator is no longer visible.

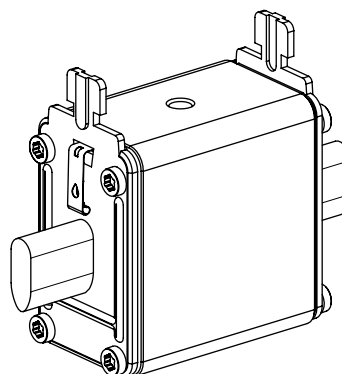
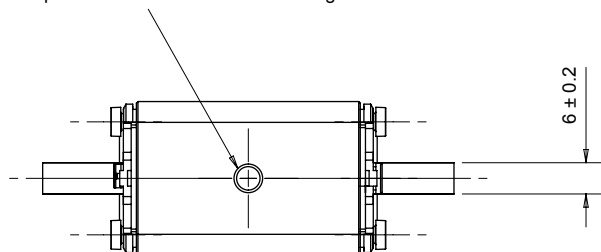

Dimensions in mm

NH fuse-links aM 500VAC

double indicator/live gripping-lugs size 000, 00, 0, 1, 2, 3

DIMENSIONS

size 0 with double indicator

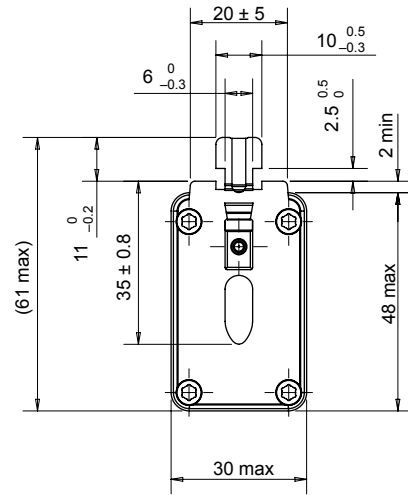
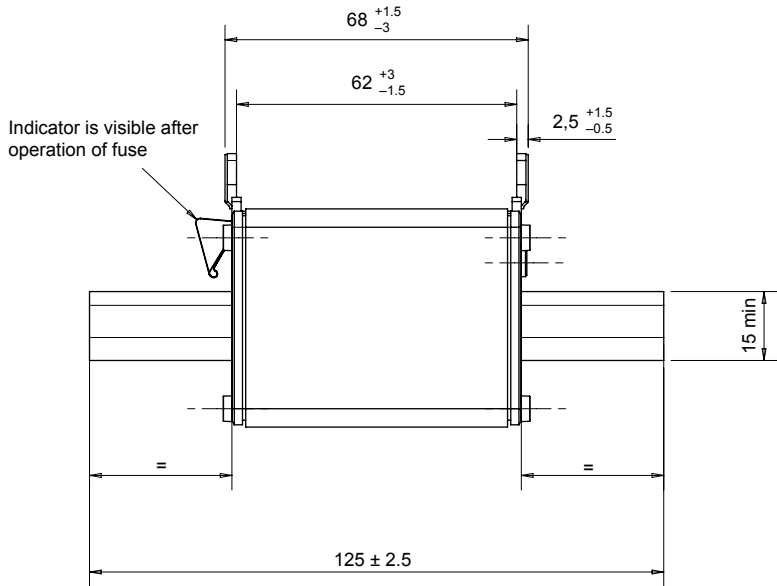

Visibility of red indicator signals conduction of the fuse-link. After operation the red indicator is no longer visible.

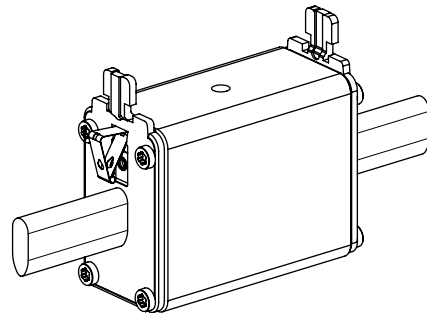
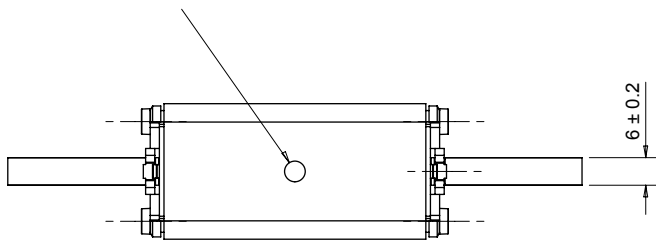

Dimensions in mm

NH fuse-links aM 500VAC

double indicator/live gripping-lugs size 000, 00, 0, 1, 2, 3

DIMENSIONS

size 1 with double indicator

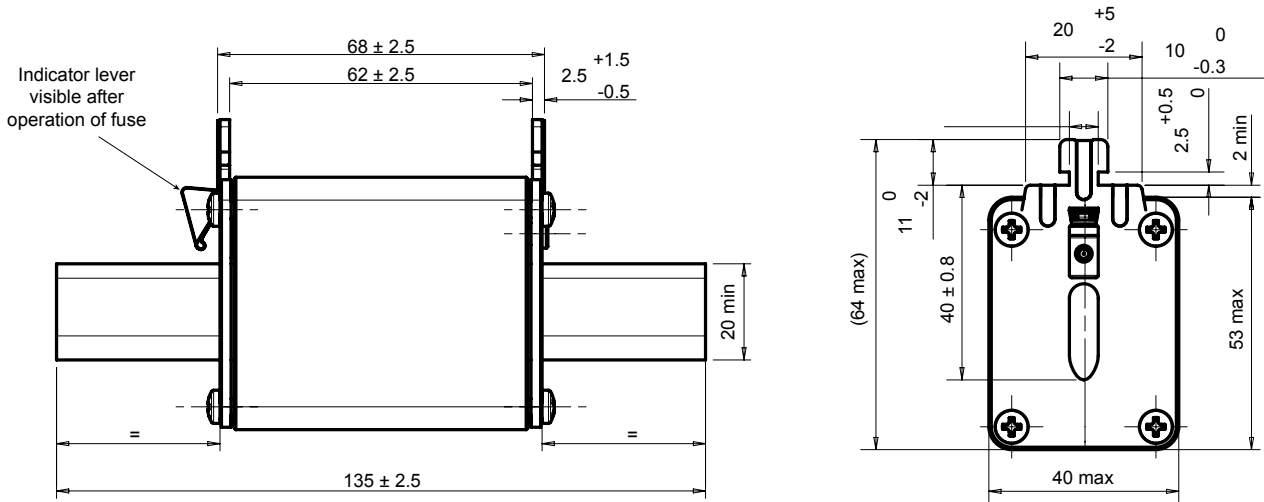

Indicator lever visible after operation of fuse

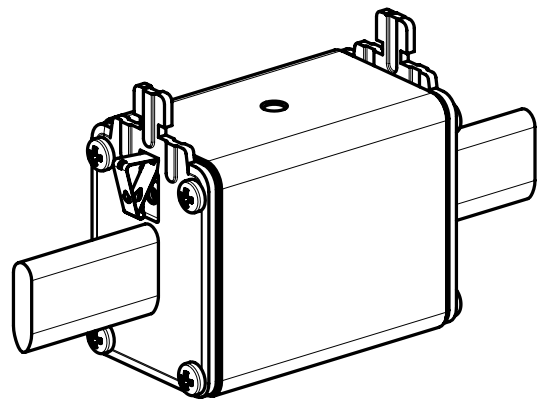
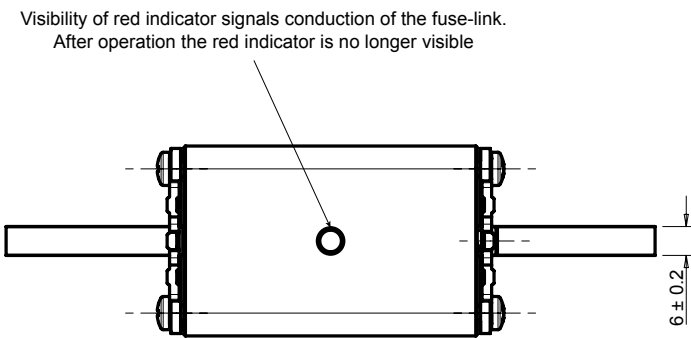

Dimensions in mm

NH fuse-links aM 500VAC

double indicator/live gripping-lugs size 000, 00, 0, 1, 2, 3

DIMENSIONS

size 2 with double indicator

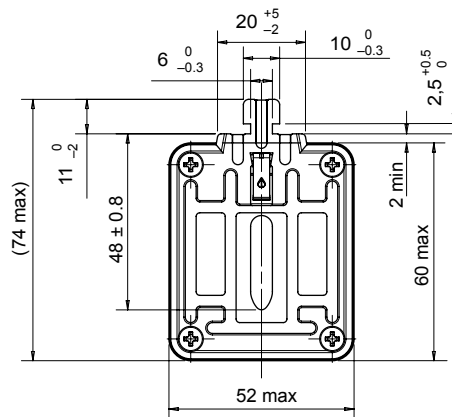
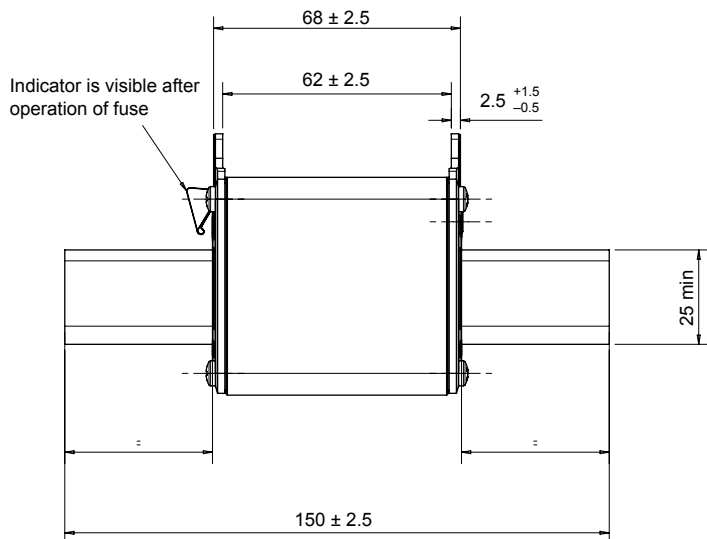

Visibility of red indicator signals conduction of the fuse-link.
After operation the red indicator is no longer visible.

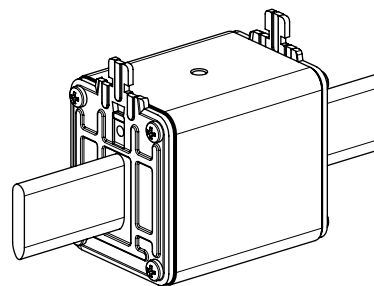
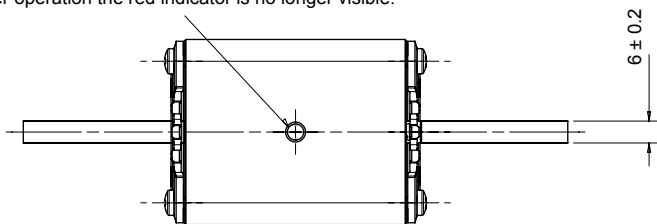

Dimensions in mm

NH fuse-links aM 500VAC

double indicator/live gripping-lugs size 000, 00, 0, 1, 2, 3

DIMENSIONS

size 3 with double indicator

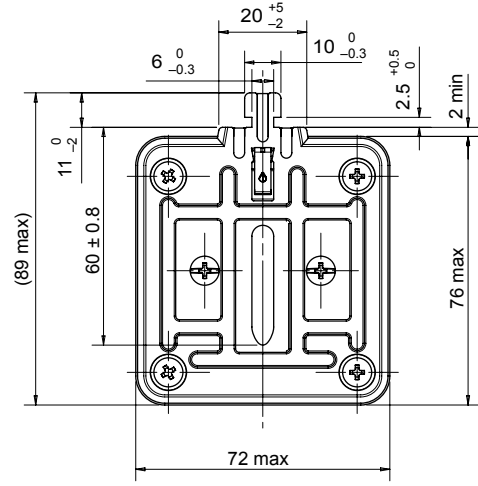
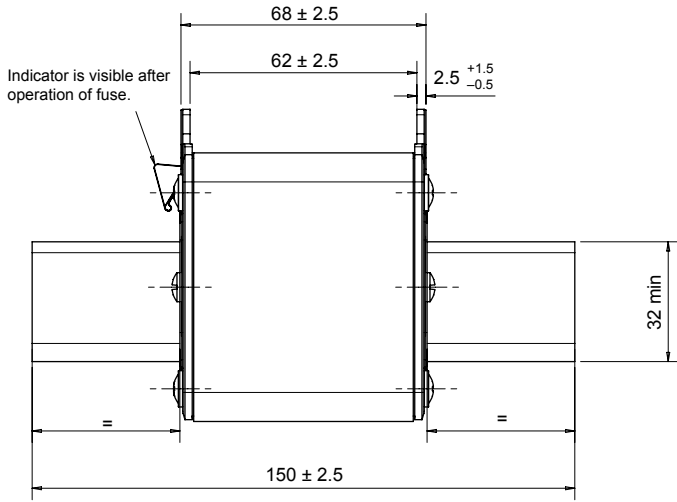

Visibility of red indicator signals conduction of the fuse-link. After operation the red indicator is no longer visible.

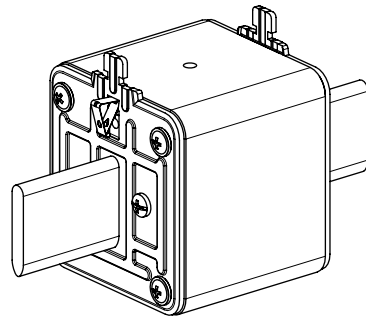
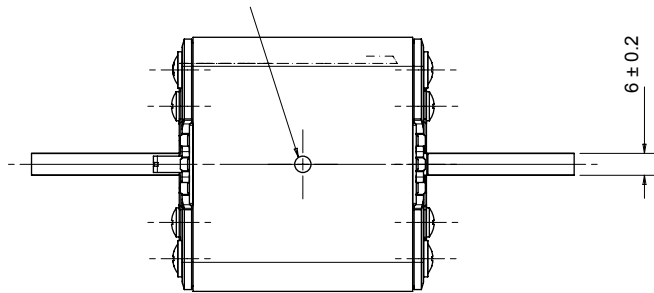

Dimensions in mm