

DALLE P31 HBM50 100 à 500  
 TRAY P31 PERF HB H50 100 to 500

GS  
 PG

**legrand** | CABLE  
 MANAGEMENT

FT0741-0

11 13

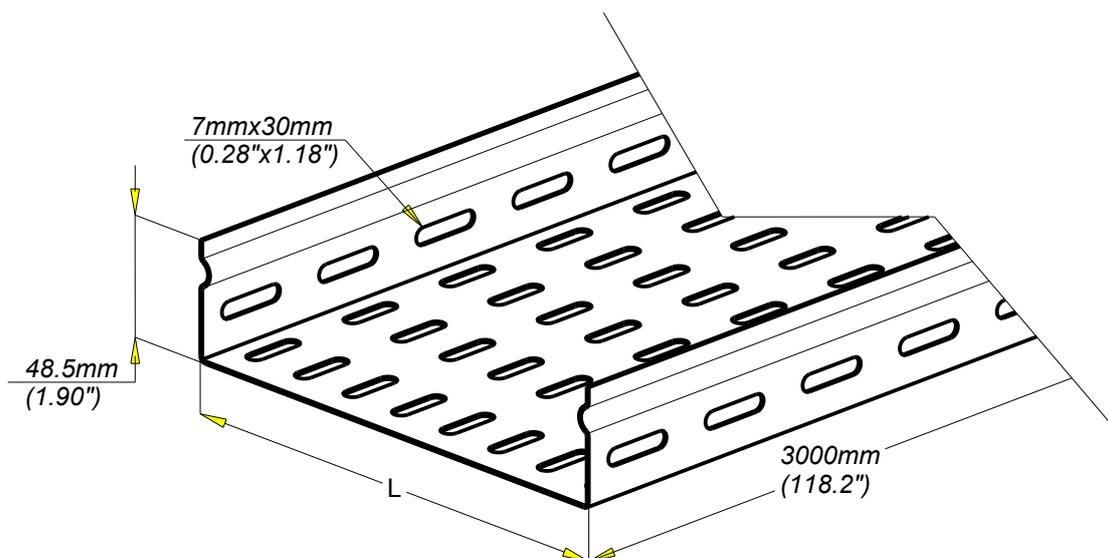
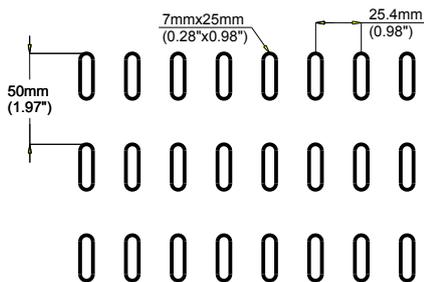

REF	CODE	POIDS /WEIGHT		L / L		EP. / TH.	
		(Kg/m)	(lb/ft)	(mm)	(inch)	(mm)	(inch)
P31 HBM 50x100	340 842	1.265	0.843	100	(3.937")	0.9	(0.035")
P31 HBM 50x150	340 843	1.917	1.278	150	(5.906")	1.1	(0.043")
P31 HBM 50x200	340 844	2.293	1.528	200	(7.874")	1.1	(0.043")
P31 HBM 50x300	340 845	3.318	2.212	300	(11.811")	1.2	(0.047")
P31 HBM 50x400	340 846	4.821	3.214	400	(15.748")	1.4	(0.055")
P31 HBM 50x500	340 847	5.778	3.852	500	(19.685")	1.4	(0.055")

<b>Material</b>	<b>Standard</b>
DX 51 D Z 275 MAC	EN 10 346