

COUDE 90 ° P31 FB H100 100 à 600  
 FLAT BEND P31 100x100 to 600

GC  
 HDG

**legrand** | CABLE  
 MANAGEMENT

FT0603-4

07 17

L = 50 to 300

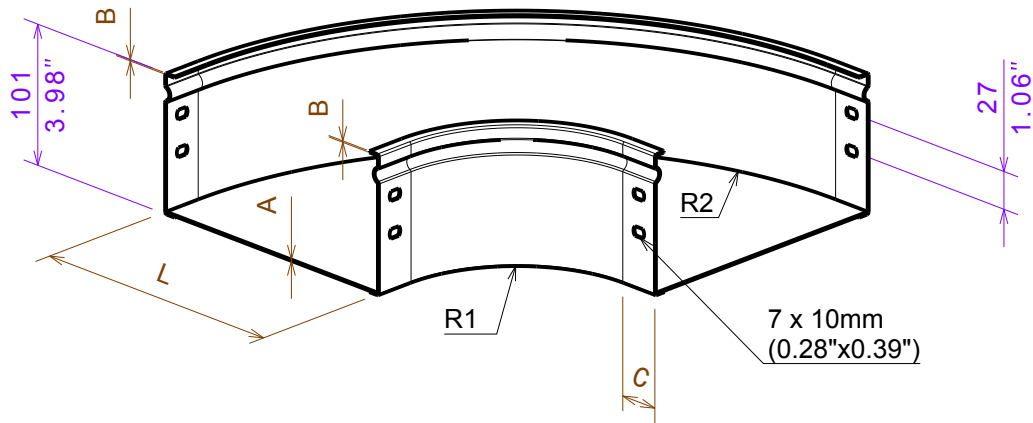

L = 400 to 600

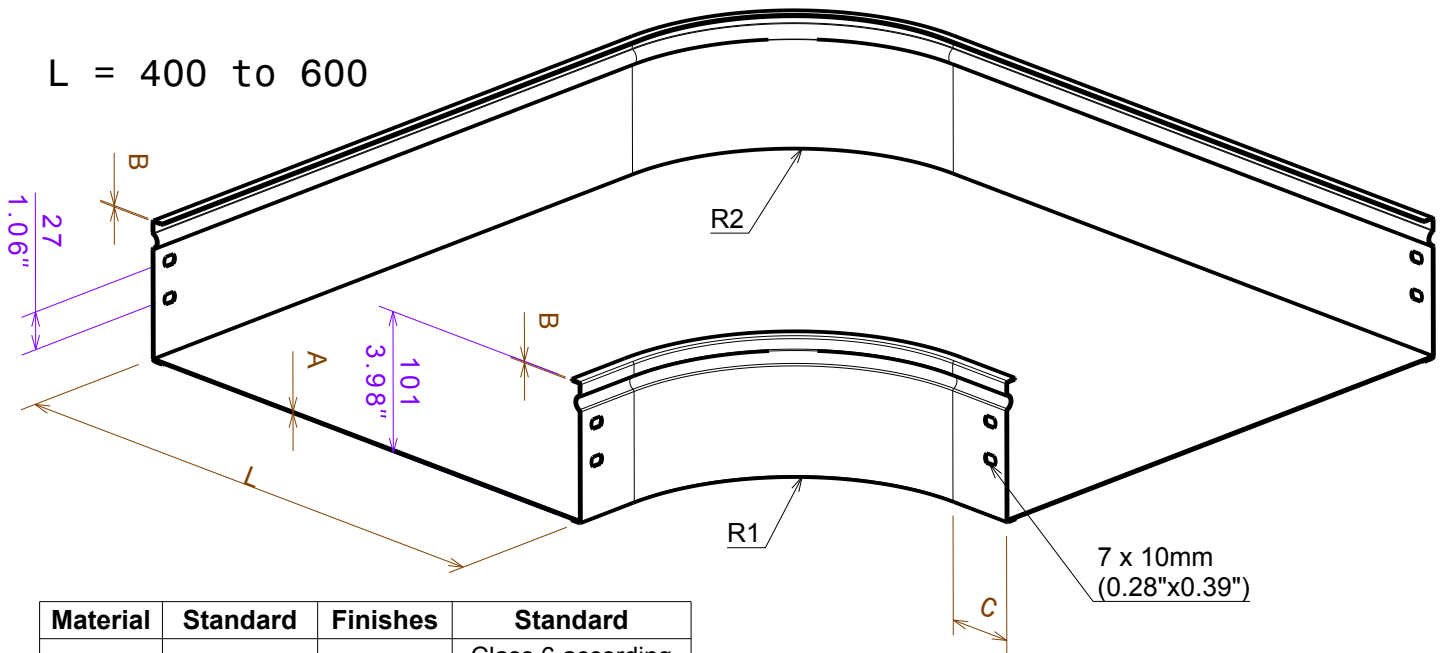

Material	Standard	Finishes	Standard
S235 JR	EN 10130	HDG	Class 6 according to CEI 61537

REF	CODE	L /L	A /A	B /B	C /C	R1 /R 1	R2 /R2
		(mm) (inch)	(mm) (inch)	(mm) (inch)	(mm) (inch)	(mm) (inch)	(mm) (inch)
P31 FB 100x100	342 930	100 (3.94")	0.8 (0.032")	1 (0.039")	30 (1.18")	100 (3.94")	200 (3.94")
P31 FB 100x150	342 931	150 (5.91")	0.8 (0.032")	1 (0.039")	30 (1.18")	100 (3.94")	250 (3.94")
P31 FB 100x200	342 932	200 (5.91")	0.8 (0.032")	1 (0.039")	30 (1.18")	100 (3.94")	300 (3.94")
P31 FB 100x300	342 933	300 (7.87")	1 (0.039")	1 (0.039")	30 (1.18")	100 (3.94")	400 (3.94")
P31 FB 100x400	342 934	400 (11.81")	1 (0.039")	1 (0.039")	50 (1.97")	150 (5.91")	150 (5.91")
P31 FB 100x500	342 935	500 (19.69")	1 (0.039")	1 (0.039")	50 (1.97")	150 (5.91")	150 (5.91")
P31 FB 100x600	350 516	600 (23.62")	1 (0.039")	1 (0.039")	50 (1.97")	150 (5.91")	150 (5.91")