

**CRAPAUD POUR ECHELLE EDF ET U24 CLMU**  
**CLMU CLAMP FOR EDF LADDER AND U24**

**ZM**  
**Z+**



**CABLE**  
**MANAGEMENT**

**FT0497-10**

**04-16**

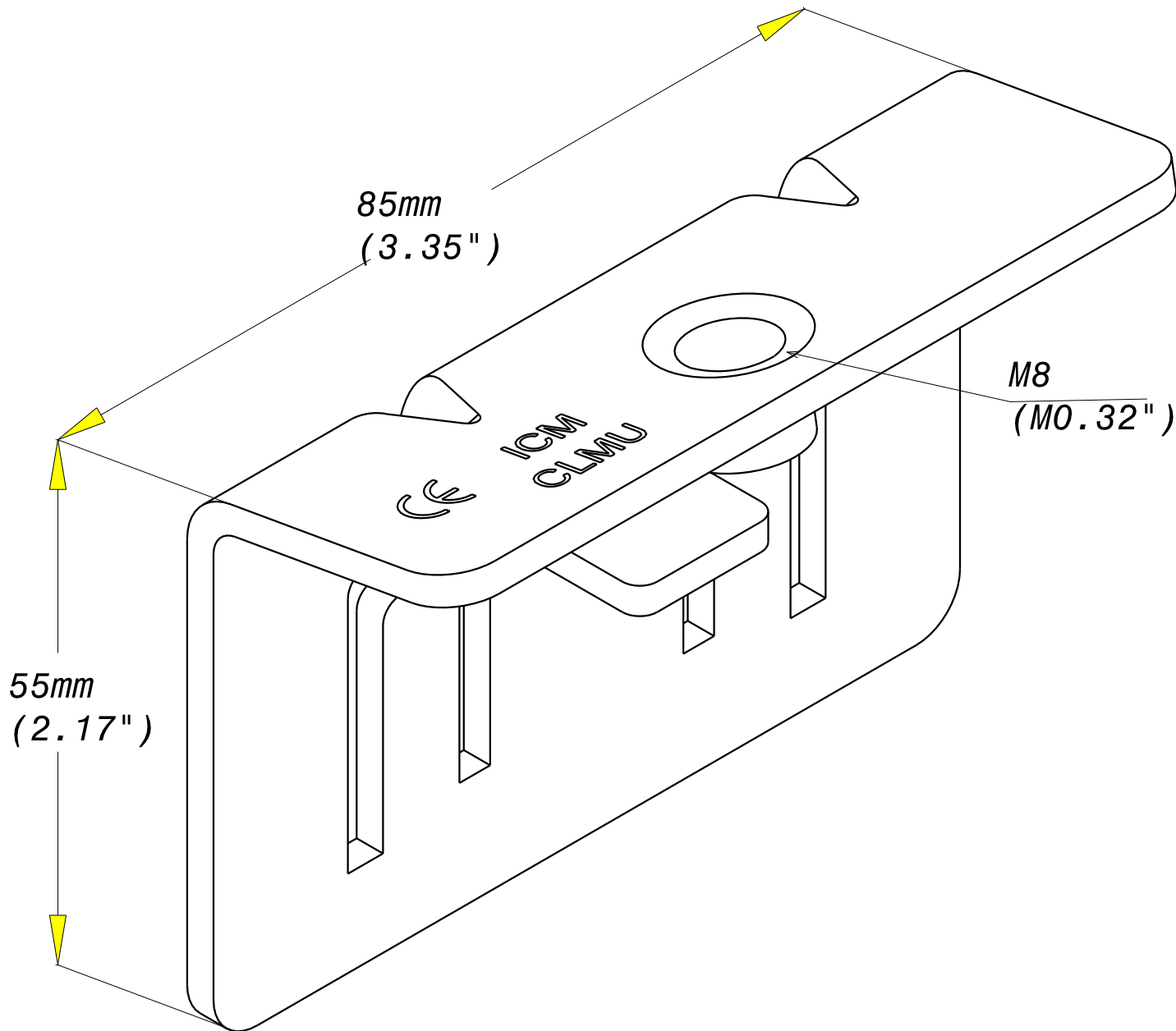

REF	CODE	POIDS (Kg)	WEIGHT (lb)	EPAISSEUR / THICKNESS
CLMU	559 097	0.150	0.330	3 (0.12")

Material	Standard
DX 51 D ZM310 MAC	EN 10 346
Finition Coating	Standard
ZM (ZnMg)	Class 6 according to CEI 61537

Propriété exclusive de LEGRAND, ne peut être ni copié, ni transmis à des tiers sans autorisation écrite.

Exclusive property of LEGRAND shouldn't be reproduced or transmitted to any people without written authorization